

# HELKAMA

THE PERFECT CONNECTION

## INDUSTRIAL CABLES OPTICAL FIBER CABLES



04/2023

# Follow the lead.

From design to manufacturing.



Helkama Bica Oy is a Finnish family enterprise with over half a century of experience in the development and production of Marine and Telecom cables. We provide solutions and manufacture different types of cables for Marine, Telecom, Industrial, Flexible, Offshore (SHF2), Optical fiber, Instrumentation and Fire-resistant applications.

Helkama Industrial Cables catalogue introduces our instrumentation, fire-resistant, optical fiber, power and data cables suitable for industrial use and a variety of applications. Our range covers cables for both indoor and outdoor use, and all Helkama industrial cables are halogen-free.

Helkama R&D team is a busy bunch continuously developing and improving the product selection to better cater for today's diverse market demands. In addition to standard cables, Helkama also designs and manufactures fully customized cables to suit customer specific requirements. If for any reason you can't find the perfect cable for your project in this or any other one of our catalogues,

no worries! Just contact our sales team for a customized solution for your project, from design to manufacturing!

The name Helkama stands for quality, flexibility and outstanding personal service. Our high technical quality has been achieved by not only continuous development work, but by working closely together with our clients. And our focus is seriously on service. Or rather, we are serious when it comes to service. Our sales team is there to help with Your project from the design phase all the way to the cables arriving on time for the construction crew on-site.

We export cables yearly to more than 60 countries worldwide, and we are known as a stable partner for several multinational corporations. Our short delivery times backed up by extensive stocks enable us to deliver punctually, giving our clients better project schedule control.

So follow the lead, and get the best cabling solution for Your projects from Helkama!





## Contents

<b>INSTRUMENTATION CABLES</b>		<b>POWER CABLES</b>	
NOVAK-HF.....	4	XCMK-HF.....	34
KJAAM-HF.....	6		
KJAAM-HF GM.....	8	<b>DATA CABLES</b>	
KLM-LSZH.....	10	CAT 6 S/FTP 4 PR AWG 26/7.....	36
KLMA-LSZH.....	12	CAT 6A S/FTP 4 PR AWG 23/1.....	38
		CAT 7 S/FTP 4 PR AWG 23/1.....	40
<b>FIRE-RESISTANT CABLES</b>		CAT 7 2XS/FTP 4 PR AWG 23/1.....	42
LifeCord (L) FRHF.....	14	CAT 7 S/FTP 4 PR AWG 24/7.....	44
Fireline 750.....	16	CAT 7 S/FTP 4 PR AWG 26/7.....	46
LifeCord FRHF.....	18	CAT 7 PUR S/FTP 4 PR AWG 26/7 PUR.....	48
LifeCord FRHF (i).....	20	CAN-BUS 1 X 2 X 0.75 120 Ω.....	50
		CAN-BUS 2 X 2 X 0.75 120 Ω.....	51
<b>OPTICAL FIBER CABLES</b>		Profibus DP 1 X 2 X AWG 22/7 -HF.....	52
LifeCord-FRHF (f).....	22		
FXMSU.....	24	<b>CHARACTERISTICS OF</b>	
FXMSU 900 μm.....	26	<b>OPTICAL FIBER CABLES</b> .....	54
FXMMS.....	28		
FMS.....	30	<b>GENERAL INFORMATION</b> .....	56
FMMS.....	32		

# NOVAK-HF

75 V

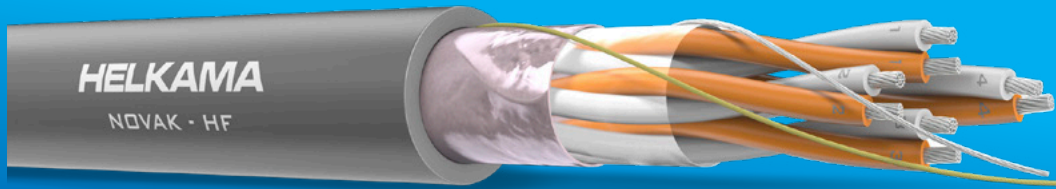

<b>CONDUCTOR</b>	Tinned copper conductor
<b>INSULATION</b>	PE
<b>TWISTED PAIR</b>	Two cores twisted together Each pair with different lay
<b>STRANDING</b>	Units of 4 pairs cabled together
<b>SCREEN</b>	Aluminium polyester tape and tinned copper drain wire
<b>SHEATH</b>	LSZH Thermoplastic Standard colour light grey
<b>REFERENCE STANDARD</b>	EN 50288-7

## APPLICATION

Cable for instrumentation, process control and computer systems. For fixed installation.

### PHYSICAL PROPERTIES:

<b>MIN. BENDING RADIUS (installation/fixed)</b>	9 x Ø/6 x Ø
<b>CORE IDENTIFICATION</b>	Pair colours white and orange Pair identification with colour code and identification number Unit identification with numbered tape

### MAIN CHARACTERISTICS:

<b>FIRE PERFORMANCE</b>	Dca s2, d2, a1
<b>RATED VOLTAGE</b>	75 V
<b>UV RESISTANCE</b>	UL1581 section 1200
<b>MIN. INSTALLATION TEMPERATURE</b>	-15 °C
<b>OPERATING TEMPERATURE</b>	-40 - 70 °C

**ELECTRICAL PROPERTIES:**

		<b>Unit</b>
Pair loop resistance (20 °C), max.	81	ohm/km
Nominal pair capacitance (800 Hz)	80	nF/km
Loop inductance	0.6	mH/km
Insulation resistance (20 °C), min.	100	Mohm/km

**NOVAK-HF**

<b>Part number</b>	<b>No. of conductors x Conductor area (mm<sup>2</sup>)</b>	<b>Nominal outer Ø mm</b>	<b>Weight kg/km</b>
3150103022	2 x 2 x 0.5 + 0.5	7.0	55
3150103042	4 x 2 x 0.5 + 0.5	8.0	80
3150103082	8 x 2 x 0.5 + 0.5	11.0	145
3150103122	12 x 2 x 0.5 + 0.5	12.0	205
3150103242	24 x 2 x 0.5 + 0.5	17.0	375

Standard length 1000 m

# KJAAM-HF

## 75 V

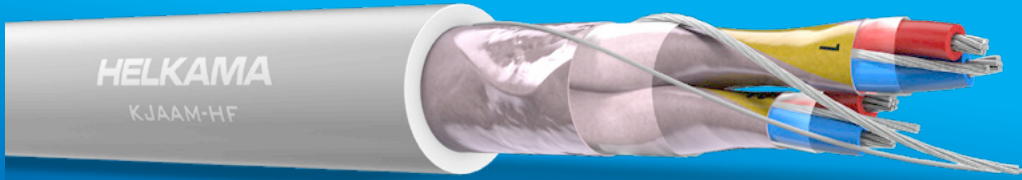

<b>CONDUCTOR</b>	Tinned copper conductor
<b>INSULATION</b>	PE
<b>TWISTED PAIR</b>	Two insulated cores twisted together
<b>INDIVIDUAL SCREEN</b>	Aluminium polyester tape and tinned copper drain wire
<b>SCREEN</b>	Aluminium polyester tape and tinned copper drain wire
<b>SHEATH</b>	LSZH Thermoplastic Standard colour light grey
<b>REFERENCE STANDARD</b>	EN 50288-7

## APPLICATION

Cable for instrumentation, process control, computer and sound reproduction systems. Designed for transmission of digital and low-level analog signals, provides excellent protection against electromagnetic interference. For fixed installation.

## PHYSICAL PROPERTIES:

<b>MIN. BENDING RADIUS (installation/fixed)</b>	9 x Ø/6 x Ø
<b>CORE IDENTIFICATION</b>	Pair colours blue/red Pair identification on numbered tape over pairs

## MAIN CHARACTERISTICS:

<b>FIRE PERFORMANCE</b>	Dca s2, d2, a1
<b>RATED VOLTAGE</b>	75 V
<b>UV RESISTANCE</b>	UL1581 section 1200
<b>MIN. INSTALLATION TEMPERATURE</b>	-15 °C
<b>OPERATING TEMPERATURE</b>	-40 - 70 °C

**ELECTRICAL PROPERTIES:**

		<b>Unit</b>
Pair DC resistance (20 °C), max.	81	ohm/km
Nominal pair capacitance (800 Hz)	100	nF/km
Loop inductance	0.6	mH/km
Insulation resistance, min.	2000	Mohm/km

**KJAAM-HF**

<b>Part number</b>	<b>No. of conductors x Conductor area (mm<sup>2</sup>)</b>	<b>Nominal outer Ø mm</b>	<b>Weight kg/km</b>
3050103012	1 x (2+1) x 0.5	4.8	33
3050103022	2 x (2+1) x 0.5 + 0.5	8.0	70
3050103042	4 x (2+1) x 0.5 + 0.5	10.0	120
3050103082	8 x (2+1) x 0.5 + 0.5	12.6	205
3050103122	12 x (2+1) x 0.5 + 0.5	15.1	286
3050103242	24 x (2+1) x 0.5 + 0.5	20.2	522

Standard length 1000 m

# KJAAM-HF GM

75 V

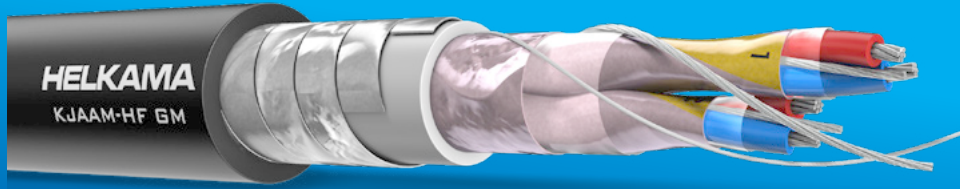

<b>CONDUCTOR</b>	Tinned copper conductor
<b>INSULATION</b>	PE
<b>TWISTED PAIR</b>	Two insulated cores twisted together
<b>INDIVIDUAL SCREEN</b>	Aluminium polyester tape and tinned copper drain wire
<b>SCREEN</b>	Aluminium polyester tape and tinned copper drain wire
<b>INNER SHEATH</b>	LSZH Thermoplastic Standard colour light grey
<b>ARMOUR</b>	Two galvanized steel tapes
<b>SHEATH</b>	LSZH Thermoplastic Standard colour black
<b>REFERENCE STANDARD</b>	EN 50288-7

## APPLICATION

Cable for instrumentation, process control, computer and sound reproduction systems. Designed for transmission of digital and low-level analog signals, provides excellent protection against electromagnetic interference. Armoured with galvanized steel tapes. For fixed installation.

### PHYSICAL PROPERTIES:

<b>MIN. BENDING RADIUS (installation/fixed)</b>	15 x Ø/10 x Ø
<b>CORE IDENTIFICATION</b>	Pair colours blue/red Pair identification on numbered tape over pairs

### MAIN CHARACTERISTICS:

<b>FIRE PERFORMANCE</b>	Fca IEC 60332-1-2 IEC 60332-3-22
<b>RATED VOLTAGE</b>	75 V
<b>UV RESISTANCE</b>	UL1581 section 1200
<b>MIN. INSTALLATION TEMPERATURE</b>	-15 °C
<b>OPERATING TEMPERATURE</b>	-40 - 70 °C



**ELECTRICAL PROPERTIES:**

		Unit
Pair DC resistance (20 °C), max.	81	ohm/km
Nominal pair capacitance (800 Hz)	100	nF/km
Loop inductance	0.6	mH/km
Insulation resistance, min.	2000	Mohm/km

**KJAAM-HF GM**

Part number	No. of conductors x Conductor area (mm <sup>2</sup> )	Nominal outer Ø mm	Weight kg/km
30212	4 x (2+1) x 0.5 + 0.5	13.2	257
30214	8 x (2+1) x 0.5 + 0.5	16.3	380
30216	12 x (2+1) x 0.5 + 0.5	19.1	527
30218	24 x (2+1) x 0.5 + 0.5	25.2	868

Standard length 1000 m



# KLM-LSZH

## 75 V

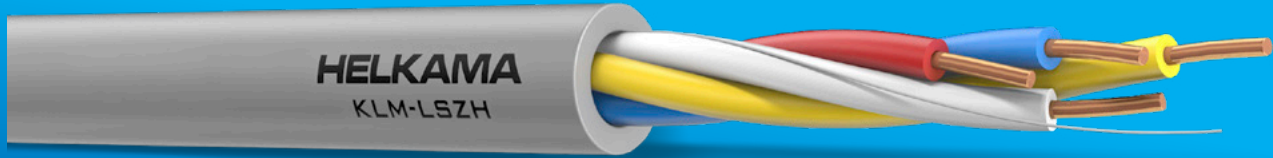

<b>CONDUCTOR</b>	Solid copper conductor
<b>INSULATION</b>	PE
<b>STRANDING</b>	Conductors twisted together
<b>SHEATH</b>	LSZH Thermoplastic Standard colours light grey, red, blue
<b>REFERENCE STANDARD</b>	EN 50288-7, SFS 2751

### APPLICATION

Cable for instrumentation, alarm systems and personal call finders. For fixed installation.

### PHYSICAL PROPERTIES:

<b>MIN. BENDING RADIUS (installation/fixed)</b>	15 x Ø/10 x Ø
<b>CORE IDENTIFICATION</b>	1. Blue 2. Yellow 3. White 4. Red

### MAIN CHARACTERISTICS:

<b>FIRE PERFORMANCE</b>	Dca, s2, d2, a1 IEC 60332-1-2
<b>RATED VOLTAGE</b>	75 V
<b>MIN. INSTALLATION TEMPERATURE</b>	-5 °C
<b>OPERATING TEMPERATURE</b>	-5 - 70 °C

**ELECTRICAL PROPERTIES:**

		Unit
Loop resistance (20 °C), max.	73.4	ohm/km
Insulation resistance, min.	> 500	Mohm x km
Test voltage DC 60 s		
Conductor/Conductor	2.25	kV

**KLM-LSZH**

Part number	No. of conductors x Conductor Ø	Nominal outer Ø mm	Weight kg/km	Colour	Standard length m	
3400225020	2 x 0.8 + 0.8	3.8 ± 0.3	19	Grey	150	coil
3402225020	2 x 0.8 + 0.8	3.8 ± 0.3	19	Grey	600	drum
3400225020	2 x 0.8 + 0.8	3.8 ± 0.3	19	Blue	150	coil
3402225020	2 x 0.8 + 0.8	3.8 ± 0.3	19	Blue	600	drum
3400225020	2 x 0.8 + 0.8	3.8 ± 0.3	19	Red	150	coil
3402225020	2 x 0.8 + 0.8	3.8 ± 0.3	19	Red	600	drum
3400225040	4 x 0.8 + 0.8	4.4 ± 0.3	32	Grey	150	coil
3402225040	4 x 0.8 + 0.8	4.4 ± 0.3	32	Grey	600	drum
3400225040	4 x 0.8 + 0.8	4.4 ± 0.3	32	Blue	150	coil
3402225040	4 x 0.8 + 0.8	4.4 ± 0.3	32	Blue	600	drum
3400225040	4 x 0.8 + 0.8	4.4 ± 0.3	32	Red	150	coil
3402225040	4 x 0.8 + 0.8	4.4 ± 0.3	32	Red	600	drum

# KLMA-LSZH

75 V

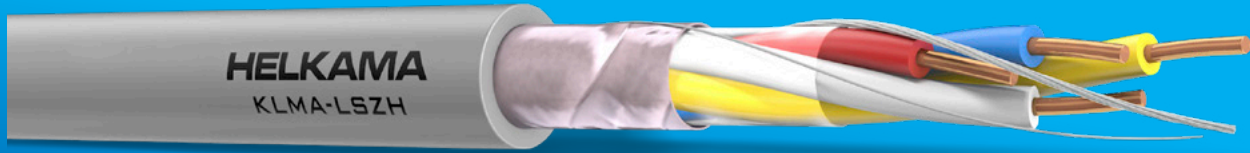

<b>CONDUCTOR</b>	Solid copper conductor
<b>INSULATION</b>	PE
<b>STRANDING</b>	Conductors twisted together Solid tinned copper drain wire under screen
<b>SCREEN</b>	Aluminium polyester tape
<b>SHEATH</b>	LSZH Thermoplastic Standard colours light grey, red, blue
<b>REFERENCE STANDARD</b>	EN 50288-7, SFS 2755

## APPLICATION

Cable for instrumentation, alarm systems and personal call finders. For fixed installation.

### PHYSICAL PROPERTIES:

<b>MIN. BENDING RADIUS (installation/fixed)</b>	15 x Ø/10 x Ø
<b>CORE IDENTIFICATION</b>	1. Blue 2. Yellow 3. White 4. Red

### MAIN CHARACTERISTICS:

<b>FIRE PERFORMANCE</b>	Dca, s2, d1, a1 IEC 60332-1-2
<b>RATED VOLTAGE</b>	75 V
<b>MIN. INSTALLATION TEMPERATURE</b>	-5 °C
<b>OPERATING TEMPERATURE</b>	-5 - 70 °C



## ELECTRICAL PROPERTIES:

		Unit
Loop resistance (20 °C), max.	73.4	ohm/km
Insulation resistance, min.	> 500	Mohm x km
Test voltage DC 60 s		
Conductor/Conductor	2.25	kV
Conductor/Screen	1.5	kV

## KLMA-LSZH

Part number	No. of conductors x Conductor Ø	Nominal outer Ø mm	Weight kg/km	Colour	Standard length m	
3410225020	2 x 0.8 + 0.8	3.9 ± 0.3	25	Grey	150	coil
3412225020	2 x 0.8 + 0.8	3.9 ± 0.3	25	Grey	600	drum
3410225020	2 x 0.8 + 0.8	3.9 ± 0.3	25	Blue	150	coil
3412225020	2 x 0.8 + 0.8	3.9 ± 0.3	25	Blue	600	drum
3410225020	2 x 0.8 + 0.8	3.9 ± 0.3	25	Red	150	coil
3412225020	2 x 0.8 + 0.8	3.9 ± 0.3	25	Red	600	drum
3410225040	4 x 0.8 + 0.8	4.5 ± 0.3	37	Grey	150	coil
3412225040	4 x 0.8 + 0.8	4.5 ± 0.3	37	Grey	600	drum
3410225040	4 x 0.8 + 0.8	4.5 ± 0.3	37	Blue	150	coil
3412225040	4 x 0.8 + 0.8	4.5 ± 0.3	37	Blue	600	drum
3410225040	4 x 0.8 + 0.8	4.5 ± 0.3	37	Red	150	coil
3412225040	4 x 0.8 + 0.8	4.5 ± 0.3	37	Red	600	drum



# LIFECORD (L) FRHF

0.6/1 kV

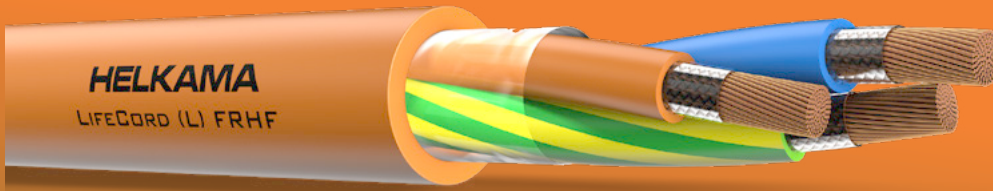

<b>CONDUCTOR</b>	1.5 mm <sup>2</sup> solid copper conductor > 1.5 mm <sup>2</sup> stranded copper conductor
<b>INSULATION</b>	Mica tape XLPE
<b>STRANDING</b>	Conductors twisted together
<b>SHEATH</b>	LSZH Thermoplastic Standard colour orange
<b>REFERENCE STANDARD</b>	IEC 60502-1 (partly)

## APPLICATION

Fire-resistant unarmoured power and control cable 0.6/1 kV. For fixed installation.

## PHYSICAL PROPERTIES:

<b>MIN. BENDING RADIUS (installation/fixed)</b>	9 x Ø/6 x Ø
<b>CORE IDENTIFICATION</b>	2 cores blue and brown 3 cores blue, brown and yellow/green 5 cores blue, brown, black, grey and yellow/green 7-27 cores black numbers on white base

## MAIN CHARACTERISTICS:

<b>FIRE PERFORMANCE</b>	IEC 60332-1-2 IEC 60332-3-22
<b>RATED VOLTAGE</b>	AC 0.6/1 kV (1.2 kV) DC 0.9/1.5 kV (if voltage to earth does not exceed 0.9 kV)
<b>FIRE-RESISTANT</b>	IEC 60331-21
<b>HALOGEN-FREE</b>	IEC 60754 series
<b>SMOKE EMISSION</b>	IEC 61034 series
<b>MIN. INSTALLATION TEMPERATURE</b>	-15 °C
<b>OPERATING TEMPERATURE</b>	-40 - 90 °C (short circuit max 5 s duration 250 °C)

## LIFECORD (L) FRHF

Part number		No. of conductors x Conductor area (mm <sup>2</sup> )	Nominal outer Ø mm	Weight kg/km
Normal	G-type			
75400		2 x 1.5	8.5	80
75401		2 x 2.5	10.0	120
75402		2 x 6	13.0	260
75403		2 x 10	15.0	385
75410	75411	3 x 1.5	9.0	105
75412	75413	3 x 2.5	10.5	150
75414	75415	3 x 6	14.0	330
75416	75417	3 x 10	16.0	485
75430	75431	5 x 1.5	11.0	165
75432	75433	5 x 2.5	12.5	225
75434	75435	5 x 6	16.7	496
75436	75437	5 x 10	19.5	736
75438		7 x 1.5	12.0	207
75439		7 x 2.5	14.0	295
75440		12 x 1.5	16.0	342
75441		12 x 2.5	18.3	480
75442		19 x 1.5	18.4	505
75443		19 x 2.5	21.6	718
75444		27 x 1.5	22.4	712
75445		27 x 2.5	26.5	1025

Standard length 500 m

G-type with yellow/green earth conductor and G-marking on sheath e.g. 3G1.5

# FIRELINE 750

500 V



<b>CONDUCTOR</b>	Solid or stranded copper conductor
<b>INSULATION</b>	Mica tape XLPE
<b>STRANDING</b>	Conductors cabled together Tinned copper drain wire under the screen
<b>SCREEN</b>	Aluminium polyester tape
<b>SHEATH</b>	LSZH Thermoplastic Standard colour red
<b>REFERENCE STANDARD</b>	EN 50288-7

## APPLICATION

Fire-resistant collectively screened instrumentation and control cable. For fixed installation.

### PHYSICAL PROPERTIES:

<b>MIN. BENDING RADIUS (installation/fixed)</b>	6 x Ø/4 x Ø
<b>CORE IDENTIFICATION</b>	2 cores blue and brown 3 cores brown, black and grey 4 cores blue, brown, black and grey 7-19 cores black numbers on white base

### MAIN CHARACTERISTICS:

<b>FIRE PERFORMANCE</b>	IEC 60332-1-2 IEC 60332-3-22
<b>RATED VOLTAGE</b>	500 V
<b>FIRE-RESISTANT</b>	IEC 60331-21
<b>UV RESISTANT</b>	IEC 60068-2-5
<b>HALOGEN-FREE</b>	IEC 60754 series
<b>SMOKE EMISSION</b>	IEC 61034 series
<b>MIN. INSTALLATION TEMPERATURE</b>	-15 °C
<b>OPERATING TEMPERATURE</b>	-40 - 70 °C
<b>MAX. CONDUCTOR TEMPERATURE</b>	90 °C



**ELECTRICAL PROPERTIES:**

	Conductor area			Unit mm <sup>2</sup>
	1	1.5	2.5	
Conductor resistance, (20 °C) max.	18.1	12.1	7.4	ohm/km
Capacitance (800 Hz)	70	80	87	nF/km
Loop inductance, max.	0.67	0.68	0.63	mH/km

**FIRELINE 750**

Part number	No. of conductors x Conductor area (mm <sup>2</sup> )	Nominal outer Ø mm	Weight kg/km
75001	2 x 1.0	7.5	80
75002	3 x 1.0	7.9	90
75003	4 x 1.0	8.5	105
75004	7 x 1.0	10.0	150
75005	12 x 1.0	13.0	240
---	19 x 1.0	15.5	340
75011	2 x 1.5	8.0	95
75012	3 x 1.5	8.5	110
75022	3 x 1.5 S*	8.5	110
75013	4 x 1.5	9.2	130
75014	7 x 1.5	11.0	195
75015	12 x 1.5	14.2	305
75016	19 x 1.5	16.5	450
75021	2 x 2.5	9.5	135
75112	3 x 2.5	9.8	155
75023	4 x 2.5	10.6	185
75024	7 x 2.5	12.6	280
75025	12 x 2.5	16.8	450
---	19 x 2.5	20.0	680

Standard length 1000 m

\* S = G-type, with yellow/green earth conductor and G-marking on sheath 3G1.5

Core identification black, blue, yellow/green

# LIFECORD-FRHF

## 300 V

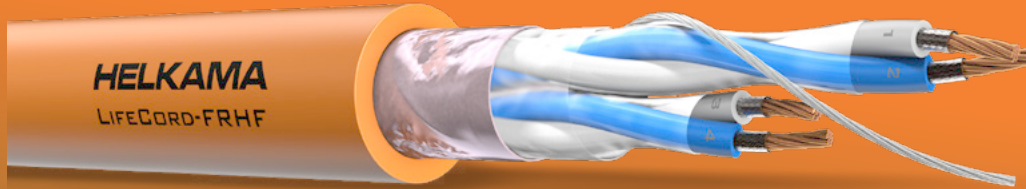

<b>CONDUCTOR</b>	Stranded copper conductor
<b>INSULATION</b>	Mica tape XLPE
<b>STRANDING</b>	Pairs cabled together Tinned copper drain wire under the screen
<b>SCREEN</b>	Aluminium polyester tape, coverage 100%
<b>SHEATH</b>	LSZH Thermoplastic Standard colour orange
<b>REFERENCE STANDARD</b>	EN 50288-7

## APPLICATION

Fire-resistant screened instrumentation and communication cable 300 V. For fixed installation where the cable has to maintain its functionality during fire.

### PHYSICAL PROPERTIES:

<b>MIN. BENDING RADIUS (installation/fixed)</b>	9 x Ø/6 x Ø
<b>CORE IDENTIFICATION</b>	Pair colours white/blue Black identification numbers

### MAIN CHARACTERISTICS:

<b>FIRE PERFORMANCE</b>	IEC 60332-1-2 IEC 60332-3-22
<b>RATED VOLTAGE</b>	300 V
<b>FIRE-RESISTANT</b>	Ø < 20 mm IEC 60331-2 Ø > 20 mm IEC 60331-1
<b>HALOGEN-FREE</b>	IEC 60754 series
<b>SMOKE EMISSION</b>	IEC 61034 series
<b>MIN. INSTALLATION TEMPERATURE</b>	-15 °C
<b>OPERATING TEMPERATURE</b>	-40 - 90 °C

**ELECTRICAL PROPERTIES:**

		<b>Unit</b>
Pair loop resistance (20 °C), max.	52	ohm/km
Nominal pair capacitance (800 Hz)	45	nF/km
Loop inductance	0.6	mH/km
Insulation resistance (20 °C), min.	≥1500	Mohm/km

**LIFECORD-FRHF**

<b>Part number</b>	<b>No. of conductors x Conductor area (mm<sup>2</sup>)</b>	<b>Nominal outer Ø mm</b>	<b>Weight kg/km</b>	<b>Standard length m</b>
0245130	1 x 2 x 0.75	8.5	75	1000
0245122	2 x 2 x 0.75	13.0	135	1000
0245124	4 x 2 x 0.75	15.5	215	1000
0245126	8 x 2 x 0.75	20.0	380	1000
0245127	12 x 2 x 0.75	24.0	545	1000
0245128	19 x 2 x 0.75	29.5	805	500
0245129	24 x 2 x 0.75	33.5	1030	500

# LIFECORD-FRHF (i)

## 300 V

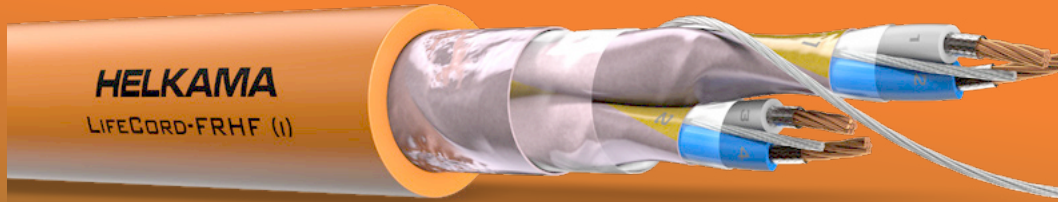

<b>CONDUCTOR</b>	Stranded copper conductor
<b>INSULATION</b>	Mica tape XLPE
<b>STRANDING</b>	Pairs and copper drain wire cabled together
<b>PAIR SCREEN</b>	Aluminium polyester tape
<b>SCREEN</b>	Aluminium polyester tape, coverage 100% Tinned copper drain wire under the screen
<b>SHEATH</b>	LSZH Thermoplastic Standard colour orange
<b>REFERENCE STANDARD</b>	EN 50288-7

## APPLICATION

Fire-resistant individually and collectively screened cable for instrumentation and communication applications. For fixed installation where the cable has to maintain its functionality during fire.

## PHYSICAL PROPERTIES:

<b>MIN. BENDING RADIUS (installation/fixed)</b>	9 x Ø/6 x Ø
<b>CORE IDENTIFICATION</b>	Pair colours white/blue Black identification numbers

## MAIN CHARACTERISTICS:

<b>FIRE PERFORMANCE</b>	IEC 60332-1-2 IEC 60332-3-22
<b>RATED VOLTAGE</b>	300 V
<b>FIRE-RESISTANT</b>	Ø < 20 mm IEC 60331-2 Ø > 20 mm IEC 60331-1
<b>HALOGEN-FREE</b>	IEC 60754 series
<b>SMOKE EMISSION</b>	IEC 61034 series
<b>MIN. INSTALLATION TEMPERATURE</b>	-15 °C
<b>OPERATING TEMPERATURE</b>	-40 - 90 °C



## ELECTRICAL PROPERTIES:

		Unit
Loop resistance of pair (20 °C), max.	52	ohm/km
Nominal pair capacitance (800 Hz)	55	nF/km
Loop inductance	0.6	mH/km
Insulation resistance (20 °C), min.	≥1500	Mohm/km

## LIFECORD-FRHF (i)

Part number	No. of conductors x Conductor area (mm <sup>2</sup> )	Nominal outer Ø mm	Weight kg/km	Standard length m
0245140	1 x 2 x 0.75	8.3	85	1000
0245142	2 x 2 x 0.75	13.5	155	1000
0245144	4 x 2 x 0.75	15.5	245	1000
0245146	8 x 2 x 0.75	20.0	430	1000
0245147	12 x 2 x 0.75	24.5	625	1000
0245148	19 x 2 x 0.75	30.0	945	500
0245149	24 x 2 x 0.75	34.0	1205	500

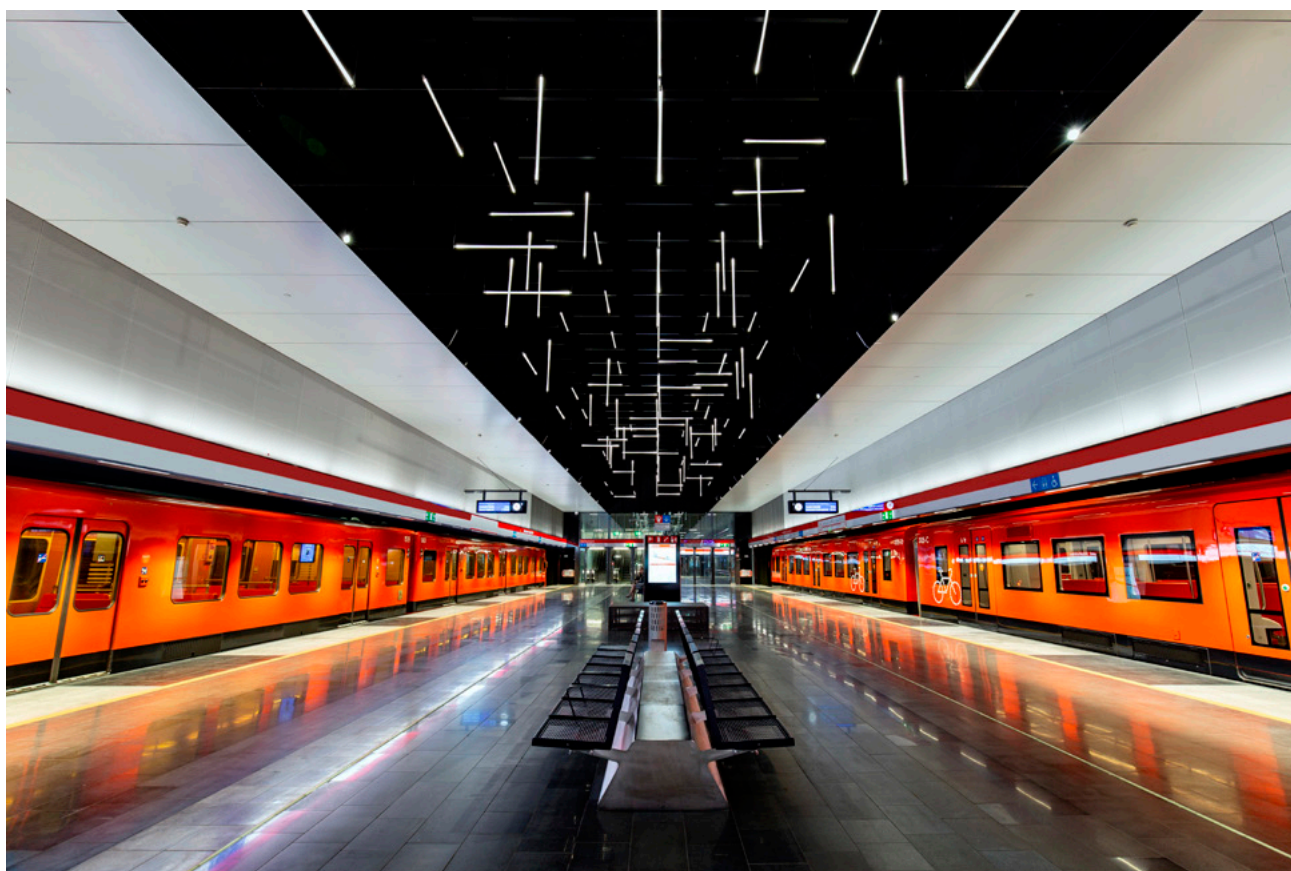

# LIFECORD-FRHF (f)

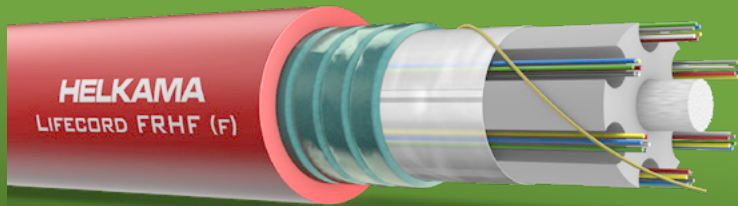

<b>CENTRAL ELEMENT</b>	Glass fiber, Ø 3.3 mm
<b>PP-SLOTTED CORE</b>	Ø 8.0 mm
<b>OPTICAL FIBERS</b>	250 µm
<b>WATER BLOCKING</b>	Water swellable tape Corrugated steel tape
<b>SHEATH</b>	LSZH Thermoplastic Standard colour red
<b>REFERENCE STANDARD</b>	Helkama specification

## APPLICATION

Fire-resistant optical fiber cable for indoor application. For fixed installation where the cable has to maintain its functionality during fire.

## PHYSICAL PROPERTIES:

		Unit	Mechanical test
<b>MAX PULLING FORCE</b>	2500	N	IEC 60794-1-2 E1
<b>CRUSH STRENGTH/ 100 mm (PLATE)</b>	7000	N	IEC 60794-1-2 E3
<b>CRUSH STRENGTH/ 25 mm (MANDREL)</b>	1500	N	IEC 60794-1-2 E3
<b>IMPACT STRENGTH</b>	50	J	IEC 60794-1-2 E4
<b>MIN. BENDING RADIUS (installation/fixed)</b>	270/200	mm	
<b>NOMINAL OUTER Ø</b>	13.5	mm	
<b>CABLE WEIGHT</b>	196	kg/km	

## MAIN CHARACTERISTICS:

<b>FIRE PERFORMANCE</b>	IEC 60332-1-2 IEC 60332-3-22
<b>FIRE-RESISTANT</b>	IEC 60331-25
<b>HALOGEN-FREE</b>	IEC 60754 series
<b>SMOKE EMISSION</b>	IEC 61034 series
<b>MIN. INSTALLATION TEMPERATURE</b>	-15 °C
<b>OPERATING TEMPERATURE</b>	-30 - 70 °C

**LIFECORD-FRHF (f)**

<b>Part number</b>	<b>Cable type</b>
15001	LifeCord FRHF 1 x 4 GKL
15005	LifeCord FRHF 1 x 4 SML
15006	LifeCord FRHF 1 x 6 SML
15008	LifeCord FRHF 2 x 6 SML
15012	LifeCord FRHF 4 x 6 SML
15020	LifeCord FRHF 1 x 4 SML + 2 x 4 GKL
15039	LifeCord FRHF 1 x 4 SML + 1 x 4 OM3L
15041	LifeCord FRHF 1 x 6 SML + 3 x 4 GKL
15043	LifeCord FRHF 2 x 6 SML + 3 x 4 GKL
15045	LifeCord FRHF 2 x 6 SML + 3 x 4 OM3L
15048	LifeCord FRHF 3 x 6 SML + 3 x 6 GKL
15062	LifeCord FRHF 2 x 4 GKL
15063	LifeCord FRHF 3 x 4 GKL
15066	LifeCord FRHF 6 x 4 GKL
15071	LifeCord FRHF 1 x 4 OM3L
15073	LifeCord FRHF 2 x 4 OM3L
15075	LifeCord FRHF 3 x 4 OM3L
15081	LifeCord FRHF 6 x 4 OM3L
15095	LifeCord FRHF 3 x 4 OM4L

Other types on request

# FXMSU

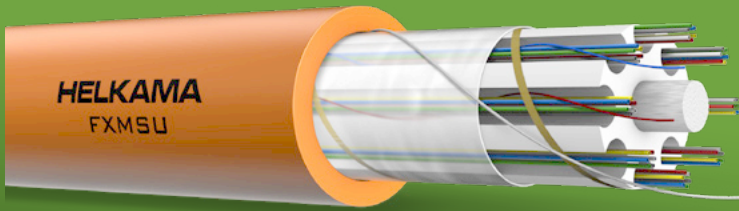

		Max 30 fibers	Max 48 fibers	Unit
<b>CENTRAL ELEMENT, GLASS FIBER</b>		1.5	3.3	Ø mm
<b>PP-SLOTTED CORE</b>		6.0	9.5	Ø mm
<b>OPTICAL FIBERS</b>		250	250	Ø µm
<b>WRAPPING</b>	Aramid binding yarn			
<b>WATER BLOCKING</b>	Water swellable tape			
<b>SHEATH</b>	LSZH Thermoplastic Standard colour orange			
<b>REFERENCE STANDARD</b>	Helkama specification			

## APPLICATION

Optical fiber cable for indoor/outdoor application.

## PHYSICAL PROPERTIES:

	Max 30 fibers	Max 48 fibers	Unit	Mechanical test
<b>TENSILE STRENGTH</b>	500	1750	N	EN 187000 method 501
<b>CRUSH STRENGTH/ 100 mm (PLATE)</b>	4000	4000	N	EN 187000 method 504
<b>CRUSH STRENGTH/ 25 mm (MANDREL)</b>	650	1000	N	EN 187000 method 504
<b>IMPACT STRENGTH</b>	25	50	J	EN 187000 method 505
<b>LONGITUDINAL WATER TIGHTNESS</b>				EN 18700 method 605B
<b>MIN. BENDING RADIUS (installation/fixed)</b>	15/10 x Ø 15/10 x Ø			
<b>NOMINAL OUTER Ø</b>	9.4	13.1	mm	
<b>CABLE WEIGHT</b>	75	146	kg/km	

## MAIN CHARACTERISTICS:

<b>FIRE PERFORMANCE</b>	Eca IEC 60332-1-2 IEC 60332-3-22
<b>UV RESISTANCE</b>	UL1581 section 1200
<b>HALOGEN-FREE</b>	IEC 60754-1
<b>ACIDITY OF COMBUSTION GASES</b>	IEC 60754-2
<b>CONDUCTIVITY OF COMBUSTION GASES</b>	IEC 60754-2
<b>SMOKE EMISSION</b>	IEC 61034 series
<b>MIN. INSTALLATION TEMPERATURE</b>	-15 °C
<b>OPERATING TEMPERATURE</b>	-45 - 70 °C

## FXMSU

Part number	Cable type
10001	FXMSU 1 x 4 SML (L)
10022	FXMSU 1 x 6 SML (L)
10003	FXMSU 2 x 4 SML (L)
10024	FXMSU 2 x 6 SML (L)
10028	FXMSU 4 x 6 SML (L)
14404	FXMSU 1 x 4 GKL (L)
14408	FXMSU 2 x 4 GKL (L)
14410	FXMSU 3 x 4 GKL (L)
14416	FXMSU 4 x 6 GKL (L)
14420	FXMSU 1 x 4 SML + 1 x 4 GKL (L)
14422	FXMSU 1 x 4 SML + 2 x 4 GKL (L)
14424	FXMSU 2 x 4 SML + 2 x 4 GKL (L)
14426	FXMSU 1 x 6 SML + 3 x 4 GKL (L)
14428	FXMSU 2 x 6 SML + 3 x 4 GKL (L)
14384	FXMSU 1 x 4 OM3L (L)
14386	FXMSU 2 x 4 OM3L (L)
14388	FXMSU 3 x 4 OM3L (L)
14398	FXMSU 4 x 6 OM3L (L)
14450	FXMSU 1 x 4 SML + 2 x 4 OM3L (L)
14451	FXMSU 2 x 4 SML + 2 x 4 OM3L (L)
14454	FXMSU 1 x 6 SML + 3 x 4 OM3L (L)
14455	FXMSU 2 x 6 SML + 3 x 4 OM3L (L)
14601	FXMSU 1 x 4 OM4L (L)
14542	FXMSU 2 x 4 OM4L (L)
14543	FXMSU 3 x 4 OM4L (L)
14614	FXMSU 4 x 6 OM4L (L)
14470	FXMSU 1 x 4 SML + 2 x 4 OM4L (L)
14472	FXMSU 2 x 4 SML + 2 x 4 OM4L (L)
14474	FXMSU 1 x 6 SML + 3 x 4 OM4L (L)
14620	FXMSU 2 x 6 SML + 3 x 4 OM4L (L)
14478	FXMSU 4 x 6 SML + 4 x 6 OM4L
10016	FXMSU 8 x 6 SML
14219	FXMSU 8 x 6 GKL
14244	FXMSU 4 x 6 SML + 4 x 6 GKL
14256	FXMSU 8 x 6 OM3L
14264	FXMSU 4 x 6 SML + 4 x 6 OM3L
14568	FXMSU 8 x 6 OM4L

Other types on request



# FXMSU 900 $\mu\text{m}$

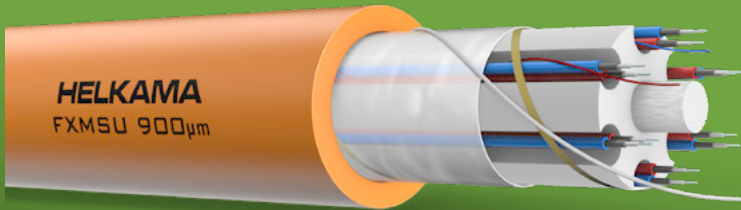

		Max 12 fibers	Unit
<b>CENTRAL ELEMENT, GLASS FIBER</b>		2.6	Ø mm
<b>PP-SLOTTED CORE</b>		9.0	Ø mm
<b>OPTICAL FIBERS</b>		900	Ø $\mu\text{m}$
<b>WRAPPING</b>	Aramid binding yarn		
<b>WATER BLOCKING</b>	Water swellable tape		
<b>SHEATH</b>	LSZH Thermoplastic Standard colour orange or black		
<b>REFERENCE STANDARD</b>	Helkama specification		

## APPLICATION

Halogen-free optical fiber cable with 900  $\mu\text{m}$  tight-buffered fiber for indoor/outdoor application.

## PHYSICAL PROPERTIES:

	Max 12 fibers	Unit	Mechanical test
<b>TENSILE STRENGTH</b>	1150	N	EN 187000 method 501
<b>CRUSH STRENGTH/ 100 mm (PLATE)</b>	4000	N	EN 187000 method 504
<b>CRUSH STRENGTH/ 25 mm (MANDREL)</b>	1000	N	EN 187000 method 504
<b>IMPACT STRENGTH</b>	30	J	EN 187000 method 505
<b>LONGITUDINAL WATER TIGHTNESS</b>			EN 18700 method 605B
<b>MIN. BENDING RADIUS (installation/fixed)</b>	15/10 x Ø		
<b>NOMINAL OUTER Ø</b>	12.4	mm	
<b>CABLE WEIGHT</b>	124	kg/km	

## MAIN CHARACTERISTICS:

<b>FIRE PERFORMANCE</b>	Eca IEC 60332-1-2 IEC 60332-3-22
<b>UV RESISTANCE</b>	UL1581 section 1200
<b>HALOGEN-FREE</b>	IEC 60754-1
<b>ACIDITY OF COMBUSTION GASES</b>	IEC 60754-2
<b>CONDUCTIVITY OF COMBUSTION GASES</b>	IEC 60754-2
<b>SMOKE EMISSION</b>	IEC 61034 series
<b>MIN. INSTALLATION TEMPERATURE</b>	-15 °C
<b>OPERATING TEMPERATURE</b>	-45 - 70 °C

FXMSU 900  $\mu\text{m}$ 

Part number	Cable type	Colour
10044	FXMSU 900 $\mu\text{m}$ 3 x 2 SMT	Orange
10046	FXMSU 900 $\mu\text{m}$ 4 x 2 SMT	Black
10047	FXMSU 900 $\mu\text{m}$ 5 x 2 SMT	Black
10048	FXMSU 900 $\mu\text{m}$ 6 x 2 SMT	Orange
10049	FXMSU 900 $\mu\text{m}$ 6 x 2 SMT	Black
14501	FXMSU 900 $\mu\text{m}$ 1 x 2 GKT	Orange
14502	FXMSU 900 $\mu\text{m}$ 2 x 2 GKT	Orange
14503	FXMSU 900 $\mu\text{m}$ 2 x 2 OM3T	Black
14504	FXMSU 900 $\mu\text{m}$ 4 x 2 GKT	Orange
14505	FXMSU 900 $\mu\text{m}$ 4 x 2 OM3T	Orange
14506	FXMSU 900 $\mu\text{m}$ 6 x 2 GKT	Orange
14507	FXMSU 900 $\mu\text{m}$ 5 x 2 GKT	Orange
14509	FXMSU 900 $\mu\text{m}$ 5 x 2 OM3T	Black
14511	FXMSU 900 $\mu\text{m}$ 4 x 2 OM3T	Black
14513	FXMSU 900 $\mu\text{m}$ 6 x 2 OM3T	Orange
14516	FXMSU 900 $\mu\text{m}$ 2 x 2 OM3T	Orange
14520	FXMSU 900 $\mu\text{m}$ 2 x 2 SMT + 2 x 2 OM3T	Black
14522	FXMSU 900 $\mu\text{m}$ 2 x 2 SMT + 4 x 2 GKT	Orange

Other types on request

# FXMMS

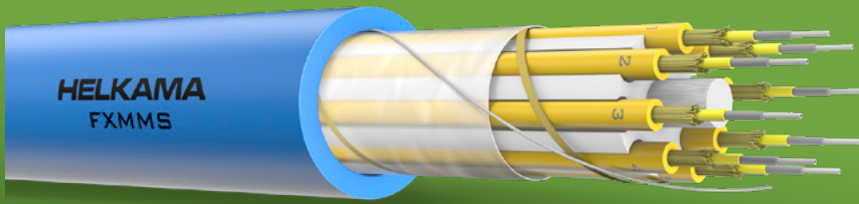

	Max 4 fibers	Max 8 fibers	Unit
<b>CENTRAL ELEMENT, GLASS FIBER</b>	2.0	2.0	Ø mm
<b>PP-SLOTTED CORE</b>	7.5	9.7	Ø mm
<b>INSTALLATION CABLE UNIT</b>	FMS 1 (2 mm) Yellow colour (SMT fibers) Green colour (GKT, OM3T and OM4T fibers)		
<b>WRAPPING</b>	Aramid binding yarn Fire barrier tape Rip cord under sheath		
<b>SHEATH</b>	LSZH Thermoplastic Standard colour blue (SMT fibers) Standard colour green (GKT, OM3T and OM4T fibers)		
<b>REFERENCE STANDARD</b>	Helkama specification		

## APPLICATION

Halogen-free optical fiber installation cable for indoor application.

## PHYSICAL PROPERTIES:

	Max 4 fibers	Max 8 fibers	Unit	Mechanical test
<b>TENSILE STRENGTH</b>	1500	1750	N	EN 187000 method 501
<b>CRUSH STRENGTH/ 100 mm (PLATE)</b>	4000	7000	N	EN 187000 method 504
<b>CRUSH STRENGTH/ 25 mm (MANDREL)</b>	750	1000	N	EN 187000 method 504
<b>IMPACT STRENGTH</b>	30	30	J	EN 187000 method 505
<b>MIN. BENDING RADIUS (installation/ fixed)</b>	15/10 x Ø	15/10 x Ø	mm	
<b>NOMINAL OUTER Ø</b>	10.7	13.1	mm	
<b>CABLE WEIGHT</b>	102	142	kg/km	

## MAIN CHARACTERISTICS:

<b>FIRE PERFORMANCE</b>	Eca IEC 60332-1 IEC 60332-3-22
<b>HALOGEN-FREE</b>	IEC 60754-1
<b>ACIDITY OF COMBUSTION GASES</b>	IEC 60754-2
<b>CONDUCTIVITY OF COMBUSTION GASES</b>	IEC 60754-2
<b>SMOKE EMISSION</b>	IEC 61034 series
<b>MIN. INSTALLATION TEMPERATURE</b>	-15 °C
<b>OPERATING TEMPERATURE</b>	-45 - 70 °C

## FXMMS

Part number	Cable type
10810	FXMMS 2 SMT (2 mm)
10812	FXMMS 4 SMT (2 mm)
10814	FXMMS 6 SMT (2 mm)
10816	FXMMS 8 SMT (2 mm)
13747	FXMMS 2 GKT (2 mm)
13748	FXMMS 4 GKT (2 mm)
13749	FXMMS 6 GKT (2 mm)
13750	FXMMS 8 GKT (2 mm)
13872	FXMMS 2 OM3T (2 mm)
13874	FXMMS 4 OM3T (2 mm)
13876	FXMMS 6 OM3T (2 mm)
13878	FXMMS 8 OM3T (2 mm)
13910	FXMMS 2 OM4T (2 mm)
13912	FXMMS 4 OM4T (2 mm)
13914	FXMMS 6 OM4T (2 mm)
13916	FXMMS 8 OM4T (2 mm)

Other types on request

# FMS



<b>OPTICAL FIBER</b>	SMT 10/125/900 $\mu\text{m}$ GKT 62.5/125/900 $\mu\text{m}$ OM3T 50/125/900 $\mu\text{m}$ OM4T 50/125/900 $\mu\text{m}$
<b>INSTALLATION CABLE UNIT</b>	1 (2 mm) / FMS 2 (2 mm) FMS 2 with separation neck
<b>SHEATH</b>	LSZH Thermoplastic Standard colour yellow (SMT fibers) Standard colour green (GKT, OM3T and OM4T fibers)
<b>REFERENCE STANDARD</b>	Helkama specification

## APPLICATION

Halogen-free installation cable.

## PHYSICAL PROPERTIES:

	FMS1	FMS2	Unit	Mechanical test
<b>TENSILE STRENGTH</b>	100	200	N	EN 187000 method 501
<b>CRUSH STRENGTH/ 100 mm (PLATE)</b>	1250	1250	N	EN 187000 method 504
<b>CRUSH STRENGTH/ 25 mm (MANDREL)</b>	100	100	N	EN 187000 method 504
<b>IMPACT STRENGTH</b>	15	15	J	EN 187000 method 505
<b>MIN. BENDING RADIUS (installation/fixed)</b>	20/12.5 x $\emptyset$			
<b>NOMINAL OUTER <math>\emptyset</math></b>	1.95	1.95 x 4.0 mm		
<b>CABLE WEIGHT</b>	3.6	7.2	kg/km	

## MAIN CHARACTERISTICS:

<b>FIRE PERFORMANCE</b>	IEC 60332-1-2
<b>HALOGEN-FREE</b>	IEC 60754-1
<b>ACIDITY OF COMBUSTION GASES</b>	IEC 60754-2
<b>CONDUCTIVITY OF COMBUSTION GASES</b>	IEC 60754-2
<b>SMOKE EMISSION</b>	IEC 61034 series
<b>MIN. INSTALLATION TEMPERATURE</b>	-15 °C
<b>OPERATING TEMPERATURE</b>	-45 - 70 °C



**FMS 1 / FMS 2**

<b>Part number</b>	<b>Cable type</b>
10806	FMS 1 SMT (2 mm)
13722	FMS 1 GKT (2 mm)
13726	FMS 1 OM3T (2 mm)
---	FMS 1 OM4T (2 mm)
10807	FMS 2 SMT (2 mm)
13723	FMS 2 GKT (2 mm)
13727	FMS 2 OM3T (2 mm)
---	FMS 2 OM4T (2 mm)

Other types on request



# FMMS



<b>OPTICAL FIBER</b>	SMT 10/125/900 $\mu\text{m}$ GKT 62.5/125/900 $\mu\text{m}$ OM3T 50/125/900 $\mu\text{m}$ OM4T 50/125/900 $\mu\text{m}$
<b>INSTALLATION CABLE UNIT</b>	FMS 1 (2 mm)
<b>SHEATH</b>	LSZH Thermoplastic Standard colour yellow (SMT fibers), Standard colour green (GKT, OM3T and OM4T fibers)
<b>REFERENCE STANDARD</b>	Helkama specification

## APPLICATION

Halogen-free 2 mm duplex installation cable.

## PHYSICAL PROPERTIES:

		Unit	Mechanical test
<b>TENSILE STRENGTH</b>	200	N	EN 187000 method 501
<b>CRUSH STRENGTH/ 100 mm (PLATE)</b>	1500	N	EN 187000 method 504
<b>CRUSH STRENGTH/ 25 mm (MANDREL)</b>	150	N	EN 187000 method 504
<b>IMPACT STRENGTH, R=300 mm</b>	20	J	EN 187000 method 505
<b>MIN. BENDING RADIUS (installation/ fixed)</b>	40/25	mm	
<b>NOMINAL OUTER Ø</b>	3.7 x 5.7	mm	
<b>CABLE WEIGHT</b>	21	kg/km	

## MAIN CHARACTERISTICS:

<b>FIRE PERFORMANCE</b>	IEC 60332-1-2
<b>HALOGEN-FREE</b>	IEC 60754-1
<b>ACIDITY OF COMBUSTION GASES</b>	IEC 60754-2
<b>CONDUCTIVITY OF COMBUSTION GASES</b>	IEC 60754-2
<b>SMOKE EMISSION</b>	IEC 61034 series
<b>MIN. INSTALLATION TEMPERATURE</b>	-15 °C
<b>OPERATING TEMPERATURE</b>	-20 - 60 °C

**FMMS**

Part number	Cable type
10706	FMMS 2 SMT (2 mm)
13782	FMMS 2 GKT (2 mm)
13784	FMMS 2 OM3T (2 mm)
13785	FMMS 2 OM4T (2 mm)

Other types on request



# XCMK-HF

## 0.6/1 kV



<b>CONDUCTOR</b>	Stranded copper conductor, IEC 60228 / class 2 (class 5 on request)	
<b>INSULATION</b>	XLPE	
<b>STRANDING</b>	Parallel Cores (concentric) Extruded Filler (concentric)	Stranded Cores (braided) Dummy cores (braided)
<b>SCREEN</b>	Concentric conductor 2.5 mm <sup>2</sup>	Braided 6-16 mm <sup>2</sup>
<b>SHEATH</b>	LSZH Thermoplastic Standard colour black, other colours on request	
<b>REFERENCE STANDARD</b>	IEC 60502-1	

### APPLICATION

Flame retardant, screened power supply cable for fixed installations.

### PHYSICAL PROPERTIES:

<b>MIN. BENDING RADIUS (installation/fixed)</b>	9 x Ø/6 x Ø
<b>CORE IDENTIFICATION</b>	Brown and blue

### MAIN CHARACTERISTICS:

<b>FIRE PERFORMANCE</b>	Dca s2, d2, a1
<b>RATED VOLTAGE</b>	AC 0.6/1 kV (1.2 kV) DC 0.9/1.5 kV (if voltage to earth does not exceed 0.9 kV)
<b>UV RESISTANCE</b>	IEC 68-2-5
<b>HALOGEN-FREE</b>	IEC 60754 series
<b>MAXIMUM CONDUCTOR TEMPERATURE</b>	90 °C
<b>MIN. INSTALLATION TEMPERATURE</b>	-15 °C
<b>OPERATING TEMPERATURE</b>	-40 - 80 °C fixed installation



**XCMK-HF 1 kV CONCENTRIC CONDUCTOR**

Part number	No. of conductors x Conductor area (mm <sup>2</sup> )	No. of wires x Ø of wires (mm)	Screen area (mm <sup>2</sup> )	Nominal outer Ø (mm)	Weight kg/km	Current rating A
6030409020	2 x 4	7 x 0.85	2.5	12.9	265	34
6030410020	2 x 6	7 x 1.05	2.5	14.1	331	44
6030411020	2 x 10	7 x 1.35	2.5	15.9	454	61
6030412020	2 x 16	19 x 1.04	2.5	18.4	612	82
6030413020	2 x 25	37 x 0.93	2.5	21.8	833	108
6030414020	2 x 35	37 x 1.1	2.5	24.2	1055	133

Standard length 1000 m

**XCMK-HF 1 kV BRAIDED**

Part number	No. of conductors x Conductor area (mm <sup>2</sup> )	No. of wires x Ø of wires (mm)	Screen area (mm <sup>2</sup> )	Nominal outer Ø (mm)	Weight kg/km	Current rating A
6030210020	2 x 6/6	7 x 1.05	6	13.7	319	44
6030211020	2 x 10/10	7 x 1.35	10	16.0	455	61
6030212020	2 x 16/16	19 x 1.04	16	18.3	660	82
6030213020	2 x 25/16	37 x 0.93	16	22.1	891	108
6030214020	2 x 35/16	37 x 1.1	16	24.5	1124	133

Standard length 1000 m





# CAT 6

## S/FTP 4 PR AWG 26/7

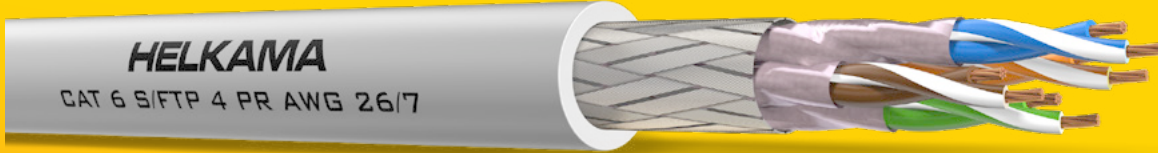

<b>CONDUCTOR</b>	Stranded copper conductor 26 AWG/7
<b>INSULATION</b>	Foam PE
<b>PAIR SHIELDING</b>	Aluminium foil
<b>SHIELDING</b>	Tinned copper wire braid
<b>SHEATH</b>	LSZH
<b>REFERENCE STANDARD</b>	IEC 61156-6 & ISO/IEC 11801

### PHYSICAL PROPERTIES:

<b>BENDING RADIUS (Installation)</b>	8 x Ø
<b>MAX. RECOMMENDED PULLING TENSION</b>	80 N
<b>NOMINAL OUTER Ø</b>	6.1 ± 0.3 mm
<b>CABLE WEIGHT</b>	37 kg/km
<b>CORE IDENTIFICATION Pair colours</b>	1. White/Blue stripe & Blue 2. White/Orange stripe & Orange 3. White/Green stripe & Green 4. White/Brown stripe & Brown
<b>PACKAGING</b>	500 m drum

### MAIN CHARACTERISTICS:

<b>FIRE PERFORMANCE</b>	IEC 60332-1 IEC 60332-3-22
<b>HALOGEN-FREE</b>	IEC 60754 series
<b>SMOKE EMISSION</b>	IEC 61034 series
<b>MAX. CONDUCTOR DC RESISTANCE</b>	145 Ω/km @20 °C
<b>CONDUCTOR LOOP RESISTANCE</b>	max. 29 Ω/100 m @20 °C
<b>NOM. MUTUAL CAPACITANCE</b>	≤ 5.6 nF/100 m @1 kHz
<b>CAPACITANCE UNBALANCE PAIR TO GROUND</b>	≤ 1600 pF/km @1 kHz
<b>MIN. INSULATION RESISTANCE</b>	5000 MΩ/m
<b>IMPEDANCE</b>	100 ± 25 Ω @100 MHz
<b>RATED TEMPERATURE</b>	75 °C
<b>OPERATING TEMPERATURE RANGE</b>	20 °C - 75 °C

## ITEM NUMBERS:

Part number	Cable type	Colour	Standard length m
3370149072	CAT 6 S/FTP AWG 26/7	Black	500
3370249072	CAT 6 S/FTP AWG 26/7	Yellow	500
3370349072	CAT 6 S/FTP AWG 26/7	Grey	500
3370449072	CAT 6 S/FTP AWG 26/7	White	500
3370549072	CAT 6 S/FTP AWG 26/7	Orange	500
3370649072	CAT 6 S/FTP AWG 26/7	Blue	500
3370749072	CAT 6 S/FTP AWG 26/7	Red	500
3370849072	CAT 6 S/FTP AWG 26/7	Green	500

## PERFORMANCE:

F (MHz)	ATT (dB/100 m)	RL (dB)	NEXT (dB)	PS NEXT (dB)	ACRF (EL FEXT) (dB/100 m)	PS ACRF (PS EL FEXT) (dB/100 m)	PD (ns/100 m)
1.0	2.6	34	91	84	92	89	485
4.0	4.9	33	93	85	90	87	463
8.0	7.0	35	93	88	93	90	457
10.0	7.7	38	104	97	102	99	455
16.0	9.8	34	110	103	107	104	452
20.0	11.1	34	107	101	108	105	451
25.0	12.5	39	114	107	111	108	450
31.2	14.1	39	110	104	111	108	449
62.5	20.2	40	112	106	114	111	447
100.0	25.9	43	113	107	118	115	445
200.0	36.9	35	111	103	111	108	444
250.0	41.4	28	109	103	109	106	443
300.0	45.7	29	109	103	112	109	443
400.0	53.3	38	108	101	112	109	443
500.0	60.1	31	110	97	110	107	443
600.0	66.2	27	111	102	111	108	442

**F** = Frequency

**ATT** = Attenuation

**RL** = Return Loss

**NEXT** = Near End Crosstalk

**PS NEXT** = Power Sum Near End Crosstalk

**ACRF (EL FEXT)** = Attenuation to Crosstalk Ratio Far End Crosstalk

**PS ACRF (PS EL FEXT)** = Power Sum Attenuation to Crosstalk Ratio Far End Crosstalk

**PD** = Phase Delay

# CAT 6 A

## S/FTP 4 PR AWG 23/1

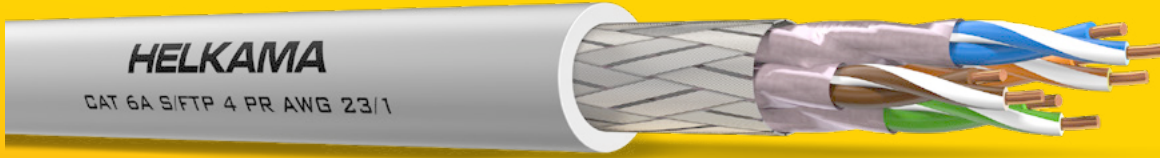

<b>CONDUCTOR</b>	Solid copper conductor 23 AWG/1
<b>INSULATION</b>	Foam PE
<b>PAIR SHIELDING</b>	Aluminium foil
<b>SHIELDING</b>	Tinned copper wire braid
<b>SHEATH</b>	LSZH
<b>REFERENCE STANDARD</b>	IEC 61156-5 & ISO/IEC 11801

### PHYSICAL PROPERTIES:

<b>BENDING RADIUS (Installation)</b>	8 x Ø
<b>MAX. RECOMMENDED PULLING TENSION</b>	80 N
<b>NOMINAL OUTER Ø</b>	7.1 ± 0.3 mm
<b>CABLE WEIGHT</b>	51 kg/km
<b>CORE IDENTIFICATION Pair colours</b>	1. White/Blue stripe & Blue 2. White/Orange stripe & Orange 3. White/Green stripe & Green 4. White/Brown stripe & Brown
<b>PACKAGING</b>	500 m drum, 1000 m drum

### MAIN CHARACTERISTICS:

<b>FIRE PERFORMANCE</b>	Dca-s1a, d1, a1 IEC 60332-1-2 IEC 60332-3-22
<b>MAX. CONDUCTOR DC RESISTANCE</b>	93.8 Ω/km @20 °C
<b>CONDUCTOR LOOP RESISTANCE</b>	max. 19 Ω/100 m @20 °C
<b>NOM. MUTUAL CAPACITANCE</b>	≤ 5.6 nF/100 m @1 kHz
<b>CAPACITANCE UNBALANCE PAIR TO GROUND</b>	≤ 1600 pF/km @1 kHz
<b>MIN. INSULATION RESISTANCE</b>	5000 MΩ/m
<b>IMPEDANCE</b>	100 ± 25 Ω @100 MHz
<b>RATED TEMPERATURE</b>	75 °C
<b>OPERATING TEMPERATURE RANGE</b>	-20 °C - 75 °C

## ITEM NUMBERS:

Part number	Cable type	Colour	Standard length m
3388124042	CAT 6A S/FTP AWG 23/1	Black	500
3388224042	CAT 6A S/FTP AWG 23/1	Yellow	500
3388324042	CAT 6A S/FTP AWG 23/1	Grey	500
3388424042	CAT 6A S/FTP AWG 23/1	White	500
3388524042	CAT 6A S/FTP AWG 23/1	Orange	500
3388624042	CAT 6A S/FTP AWG 23/1	Blue	500
3388724042	CAT 6A S/FTP AWG 23/1	Red	500
3388824042	CAT 6A S/FTP AWG 23/1	Green	500
3389124042	CAT 6A S/FTP AWG 23/1	Black	1000
3389224042	CAT 6A S/FTP AWG 23/1	Yellow	1000
3389324042	CAT 6A S/FTP AWG 23/1	Grey	1000
3389424042	CAT 6A S/FTP AWG 23/1	White	1000
3389524042	CAT 6A S/FTP AWG 23/1	Orange	1000
3389624042	CAT 6A S/FTP AWG 23/1	Blue	1000
3389724042	CAT 6A S/FTP AWG 23/1	Red	1000
3389824042	CAT 6A S/FTP AWG 23/1	Green	1000

## PERFORMANCE:

F (MHz)	ATT (dB/100 m)	RL (dB)	NEXT (dB)	PS NEXT (dB)	ACRF (EL FEXT) (dB/100 m)	PS ACRF (PS EL FEXT) (dB/100 m)	PD (ns/100 m)
1.0	1.8	26	85	82	85	83	448
4.0	3.4	35	88	83	86	82	433
8.0	4.8	38	86	84	88	82	428
10.0	5.4	36	100	96	95	92	427
16.0	6.9	40	101	98	96	93	425
20.0	7.8	38	101	97	97	93	425
25.0	8.7	41	100	98	95	90	424
31.2	9.8	38	103	100	89	87	423
62.5	14.0	43	101	97	92	88	421
100.0	17.8	42	106	101	85	82	420
200.0	25.2	37	97	94	74	71	419
250.0	28.4	31	99	97	72	70	419
300.0	31.2	32	101	97	71	68	419
400.0	36.0	30	99	96	63	60	419
500.0	40.6	22	96	95	60	58	419

**F** = Frequency**ATT** = Attenuation**RL** = Return Loss**NEXT** = Near End Crosstalk**PS NEXT** = Power Sum Near End Crosstalk**ACRF (EL FEXT)** = Attenuation to Crosstalk Ratio Far End Crosstalk**PS ACRF (PS EL FEXT)** = Power Sum Attenuation to Crosstalk Ratio Far End Crosstalk**PD** = Phase Delay

# CAT 7

## S/FTP 4 PR AWG 23/1



<b>CONDUCTOR</b>	Solid copper conductor 23 AWG/1
<b>INSULATION</b>	Foam PE
<b>PAIR SHIELDING</b>	Aluminium foil
<b>SHIELDING</b>	Tinned copper wire braid
<b>SHEATH</b>	LSZH
<b>REFERENCE STANDARD</b>	IEC 61156-5 & ISO/IEC 11801

### PHYSICAL PROPERTIES:

<b>BENDING RADIUS (Installation)</b>	8 x Ø
<b>MAX. RECOMMENDED PULLING TENSION</b>	80 N
<b>NOMINAL OUTER Ø</b>	7.7 ± 0.3 mm
<b>CABLE WEIGHT</b>	66 kg/km
<b>CORE IDENTIFICATION Pair colours</b>	<ol style="list-style-type: none"> <li>1. White/Blue stripe &amp; Blue</li> <li>2. White/Orange stripe &amp; Orange</li> <li>3. White/Green stripe &amp; Green</li> <li>4. White/Brown stripe &amp; Brown</li> </ol>
<b>PACKAGING</b>	500 m drum, 1000 m drum

### MAIN CHARACTERISTICS:

<b>FIRE PERFORMANCE</b>	IEC 60332-1-2 IEC 60332-3-22
<b>MAX. CONDUCTOR DC RESISTANCE</b>	95 Ω/km @20 °C
<b>CONDUCTOR LOOP RESISTANCE</b>	max. 19 Ω/100 m @20 °C
<b>NOM. MUTUAL CAPACITANCE</b>	≤ 5.6 nF/100 m @1 kHz
<b>CAPACITANCE UNBALANCE PAIR TO GROUND</b>	≤ 1600 pF/km @1 kHz
<b>MIN. INSULATION RESISTANCE</b>	5000 MΩ/m
<b>IMPEDANCE</b>	100 ± 25 Ω @100 MHz
<b>RATED TEMPERATURE</b>	75 °C
<b>OPERATING TEMPERATURE RANGE</b>	-20 °C - 75 °C



Part number	Cable type	Colour	Standard length m
3340124042	CAT 7 S/FTP AWG 23/1	Black	500
3340224042	CAT 7 S/FTP AWG 23/1	Yellow	500
3340324042	CAT 7 S/FTP AWG 23/1	Grey	500
3340424042	CAT 7 S/FTP AWG 23/1	White	500
3340524042	CAT 7 S/FTP AWG 23/1	Orange	500
3340624042	CAT 7 S/FTP AWG 23/1	Blue	500
3340724042	CAT 7 S/FTP AWG 23/1	Red	500
3340824042	CAT 7 S/FTP AWG 23/1	Green	500
3341124042	CAT 7 S/FTP AWG 23/1	Black	1000
3341224042	CAT 7 S/FTP AWG 23/1	Yellow	1000
3341324042	CAT 7 S/FTP AWG 23/1	Grey	1000
3341424042	CAT 7 S/FTP AWG 23/1	White	1000
3341524042	CAT 7 S/FTP AWG 23/1	Orange	1000
3341624042	CAT 7 S/FTP AWG 23/1	Blue	1000
3341724042	CAT 7 S/FTP AWG 23/1	Red	1000
3341824042	CAT 7 S/FTP AWG 23/1	Green	1000

## PERFORMANCE:

F (MHz)	ATT (dB/100 m)	RL (dB)	NEXT (dB)	PS NEXT (dB)	ACRF (EL FEXT) (dB/100 m)	PS ACRF (PS EL FEXT) (dB/100 m)	PD (ns/100 m)
4.0	3.6	30	98	95	96	92	449
8.0	5.0	32	98	95	94	89	444
10.0	5.6	35	98	95	91	90	442
16.0	7.2	35	98	95	81	76	440
20.0	8.1	38	99	96	81	77	439
25.0	9.1	39	98	95	84	76	438
31.2	10.0	39	97	94	83	77	437
62.5	14.5	34	95	92	79	76	436
100.0	17.7	32	92	89	82	73	435
200.0	26.1	30	88	85	69	66	434
250.0	27.9	28	86	83	74	65	434
300.0	31.9	27	86	83	69	64	433
400.0	37.8	28	83	80	59	56	433
500.0	40.7	23	81	78	56	51	433
600.0	45.8	25	80	77	58	52	433

**F** = Frequency

**ATT** = Attenuation

**RL** = Return Loss

**NEXT** = Near End Crosstalk

**PS NEXT** = Power Sum Near End Crosstalk

**ACRF (EL FEXT)** = Attenuation to Crosstalk Ratio Far End Crosstalk

**PS ACRF (PS EL FEXT)** = Power Sum Attenuation to Crosstalk Ratio Far End Crosstalk

**PD** = Phase Delay

# CAT 7

## 2XS/FTP 4 PR AWG 23/1

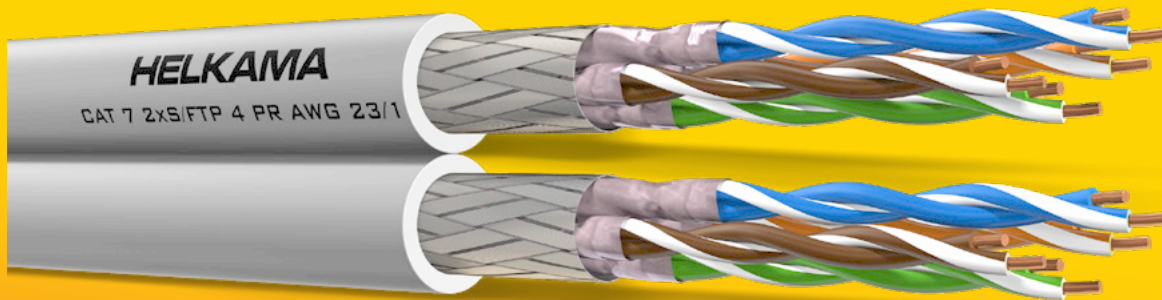

<b>CONDUCTOR</b>	Solid copper conductor 23 AWG/1
<b>INSULATION</b>	Foam PE
<b>PAIR SHIELDING</b>	Aluminium foil
<b>SHIELDING</b>	Tinned copper wire braid
<b>SHEATH</b>	LSZH
<b>REFERENCE STANDARD</b>	IEC 61156-5 & ISO/IEC 11801

### PHYSICAL PROPERTIES:

<b>BENDING RADIUS (Installation)</b>	8 x Ø
<b>MAX. RECOMMENDED PULLING TENSION</b>	80 N
<b>NOMINAL OUTER Ø</b>	7.1 ± 0.3 mm X 14.3 ± 1 mm
<b>CABLE WEIGHT</b>	132 kg/km
<b>CORE IDENTIFICATION Pair colours</b>	1. White/Blue stripe & Blue 2. White/Orange stripe & Orange 3. White/Green stripe & Green 4. White/Brown stripe & Brown
<b>PACKAGING</b>	500 m drum, 1000 m drum

### MAIN CHARACTERISTICS:

<b>FIRE PERFORMANCE</b>	Dca-s1a, d2, a1 IEC 60332-1-2 IEC 60332-3-22
<b>MAX. CONDUCTOR DC RESISTANCE</b>	95 Ω/km @20 °C
<b>CONDUCTOR LOOP RESISTANCE</b>	max. 19 Ω/100 m @20 °C
<b>NOM. MUTUAL CAPACITANCE</b>	≤ 5.6 nF/100 m @1 kHz
<b>CAPACITANCE UNBALANCE PAIR TO GROUND</b>	≤ 1600 pF/km @1 kHz
<b>MIN. INSULATION RESISTANCE</b>	5000 MΩ/m
<b>IMPEDANCE</b>	100 ± 25 Ω @100 MHz
<b>RATED TEMPERATURE</b>	75 °C
<b>OPERATING TEMPERATURE RANGE</b>	-20 °C - 75 °C

## ITEM NUMBERS:

Part number	Cable type	Colour	Standard length m
3340124082	CAT 7 2xS/FTP AWG 23/1	Black	500
3340224082	CAT 7 2xS/FTP AWG 23/1	Yellow	500
3340324082	CAT 7 2xS/FTP AWG 23/1	Grey	500
3340424082	CAT 7 2xS/FTP AWG 23/1	White	500
3340524082	CAT 7 2xS/FTP AWG 23/1	Orange	500
3340624082	CAT 7 2xS/FTP AWG 23/1	Blue	500
3340724082	CAT 7 2xS/FTP AWG 23/1	Red	500
3340824082	CAT 7 2xS/FTP AWG 23/1	Green	500

## PERFORMANCE:

F (MHz)	ATT (dB/100 m)	RL (dB)	NEXT (dB)	PS NEXT (dB)	ACRF (EL FEXT) (dB/100 m)	PS ACRF (PS EL FEXT) (dB/100 m)	PD (ns/100 m)
4.0	3.6	30	98	95	96	92	449
8.0	5.0	32	98	95	94	89	444
10.0	5.6	35	98	95	91	90	442
16.0	7.2	35	98	95	81	76	440
20.0	8.1	38	99	96	81	77	439
25.0	9.1	39	98	95	84	76	438
31.2	10.0	39	97	94	83	77	437
62.5	14.5	34	95	92	79	76	436
100.0	17.7	32	92	89	82	73	435
200.0	26.1	30	88	85	69	66	434
250.0	27.9	28	86	83	74	65	434
300.0	31.9	27	86	83	69	64	433
400.0	37.8	28	83	80	59	56	433
500.0	40.7	23	81	78	56	51	433
600.0	45.8	25	80	77	58	52	433

**F** = Frequency

**ATT** = Attenuation

**RL** = Return Loss

**NEXT** = Near End Crosstalk

**PS NEXT** = Power Sum Near End Crosstalk

**ACRF (EL FEXT)** = Attenuation to Crosstalk Ratio Far End Crosstalk

**PS ACRF (PS EL FEXT)** = Power Sum Attenuation to Crosstalk Ratio Far End Crosstalk

**PD** = Phase Delay

# CAT 7

## S/FTP 4PR AWG 24/7

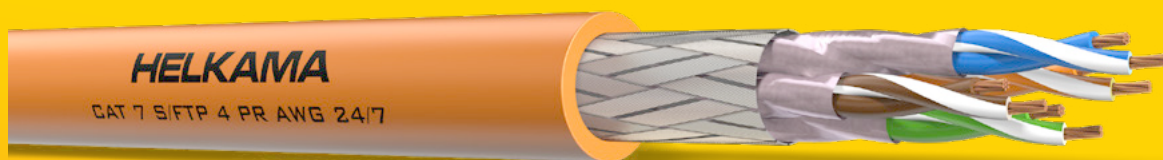

<b>CONDUCTOR</b>	Stranded copper conductor 24 AWG/7
<b>INSULATION</b>	Foam PE
<b>PAIR SHIELDING</b>	Aluminium foil
<b>SHIELDING</b>	Tinned copper wire braid
<b>SHEATH</b>	LSZH
<b>REFERENCE STANDARD</b>	IEC 61156-6 & ISO/IEC 11801

### PHYSICAL PROPERTIES:

<b>BENDING RADIUS (Installation)</b>	8 x Ø
<b>MAX. RECOMMENDED PULLING TENSION</b>	80 N
<b>NOMINAL OUTER Ø</b>	7.6 ± 0.3 mm
<b>CABLE WEIGHT</b>	61 kg/km
<b>CORE IDENTIFICATION Pair colours</b>	1. White/Blue stripe & Blue 2. White/Orange stripe & Orange 3. White/Green stripe & Green 4. White/Brown stripe & Brown
<b>PACKAGING</b>	500 m drum, 1000 m drum

### MAIN CHARACTERISTICS:

<b>FIRE PERFORMANCE</b>	IEC 60332-1 IEC 60332-3-22
<b>HALOGEN-FREE</b>	IEC 60754 series
<b>SMOKE EMISSION</b>	IEC 61034 series
<b>MAX. CONDUCTOR DC RESISTANCE</b>	148 Ω/km @20 °C
<b>CONDUCTOR LOOP RESISTANCE</b>	max. 29 Ω/100 m @20 °C
<b>NOM. MUTUAL CAPACITANCE</b>	≤ 5.6 nF/100 m @1 kHz
<b>CAPACITANCE UNBALANCE PAIR TO GROUND</b>	≤ 1600 pF/km @1 kHz
<b>MIN. INSULATION RESISTANCE</b>	5000 MΩ/m
<b>IMPEDANCE</b>	100 ± 25 Ω @100 MHz
<b>RATED TEMPERATURE</b>	80 °C
<b>OPERATING TEMPERATURE RANGE</b>	-20 °C - 75 °C

## ITEM NUMBERS:

Part number	Cable type	Colour	Standard length m
3360124042	CAT 7 S/FTP AWG 24/7	Black	500
3360224042	CAT 7 S/FTP AWG 24/7	Yellow	500
3360324042	CAT 7 S/FTP AWG 24/7	Grey	500
3360424042	CAT 7 S/FTP AWG 24/7	White	500
3360524042	CAT 7 S/FTP AWG 24/7	Orange	500
3360624042	CAT 7 S/FTP AWG 24/7	Blue	500
3360724042	CAT 7 S/FTP AWG 24/7	Red	500
3360824042	CAT 7 S/FTP AWG 24/7	Green	500
3361124042	CAT 7 S/FTP AWG 24/7	Black	1000
3361224042	CAT 7 S/FTP AWG 24/7	Yellow	1000
3361324042	CAT 7 S/FTP AWG 24/7	Grey	1000
3361424042	CAT 7 S/FTP AWG 24/7	White	1000
3361524042	CAT 7 S/FTP AWG 24/7	Orange	1000
3361624042	CAT 7 S/FTP AWG 24/7	Blue	1000
3361724042	CAT 7 S/FTP AWG 24/7	Red	1000
3361824042	CAT 7 S/FTP AWG 24/7	Green	1000

## PERFORMANCE:

F (MHz)	ATT (dB/100 m)	RL (dB)	NEXT (dB)	PS NEXT (dB)	ACRF (EL FEXT) (dB/100 m)	PS ACRF (PS EL FEXT) (dB/100 m)	PD (ns/100 m)
1.0	2.6	34	91	84	92	89	485
4.0	4.9	33	93	85	90	87	463
8.0	7.0	35	93	88	93	90	457
10.0	7.7	38	104	97	102	99	455
16.0	9.8	34	110	103	107	104	452
20.0	11.1	34	107	101	108	105	451
25.0	12.5	39	114	107	111	108	450
31.2	14.1	39	110	104	111	108	449
62.5	20.2	40	112	106	114	111	447
100.0	25.9	43	113	107	118	115	445
200.0	36.9	35	111	103	111	108	444
250.0	41.4	28	109	103	109	106	443
300.0	45.7	29	109	103	112	109	443
400.0	53.3	38	108	101	112	109	443
500.0	60.1	31	110	97	110	107	443
600.0	66.2	27	111	102	111	108	442

F = Frequency

ATT = Attenuation

RL = Return Loss

NEXT = Near End Crosstalk

PS NEXT = Power Sum Near End Crosstalk

ACRF (EL FEXT) = Attenuation to Crosstalk Ratio Far End Crosstalk

PS ACRF (PS EL FEXT) = Power Sum Attenuation to Crosstalk Ratio Far End Crosstalk

PD = Phase Delay

# CAT 7

## S/FTP 4 PR AWG 26/7



<b>CONDUCTOR</b>	Stranded tinned copper conductor 26 AWG/7
<b>INSULATION</b>	Foam PE
<b>PAIR SHIELDING</b>	Aluminium foil
<b>SHIELDING</b>	Tinned copper wire braid
<b>SHEATH</b>	LSZH
<b>REFERENCE STANDARD</b>	IEC 61156-6 & ISO/IEC 11801

### PHYSICAL PROPERTIES:

<b>BENDING RADIUS (Installation)</b>	8 x Ø
<b>MAX. RECOMMENDED PULLING TENSION</b>	80 N
<b>NOMINAL OUTER Ø</b>	6.4 ± 0.3 mm
<b>CABLE WEIGHT</b>	39 kg/km
<b>CORE IDENTIFICATION Pair colours</b>	1. White/Blue stripe & Blue 2. White/Orange stripe & Orange 3. White/Green stripe & Green 4. White/Brown stripe & Brown
<b>PACKAGING</b>	500 m drum, 1000 m drum

### MAIN CHARACTERISTICS:

<b>FIRE PERFORMANCE</b>	IEC 60332-1 IEC 60332-3-22
<b>HALOGEN-FREE</b>	IEC 60754 series
<b>SMOKE EMISSION</b>	IEC 61034 series
<b>MAX. CONDUCTOR DC RESISTANCE</b>	145 Ω/km @20 °C
<b>CONDUCTOR LOOP RESISTANCE</b>	max. 29 Ω/100 m @20 °C
<b>NOM. MUTUAL CAPACITANCE</b>	≤ 5.6 nF/100 m @1 kHz
<b>CAPACITANCE UNBALANCE PAIR TO GROUND</b>	≤ 1600 pF/km @1 kHz
<b>MIN. INSULATION RESISTANCE</b>	5000 MΩ/m
<b>IMPEDANCE</b>	100 ± 25 Ω @100 MHz
<b>RATED TEMPERATURE</b>	75 °C
<b>OPERATING TEMPERATURE RANGE</b>	-20 °C - 75 °C



## ITEM NUMBERS:

Part number	Cable type	Colour	Standard length m
3360149042	CAT 7 S/FTP AWG 26/7	Black	500
3360249042	CAT 7 S/FTP AWG 26/7	Yellow	500
3360349042	CAT 7 S/FTP AWG 26/7	Grey	500
3360449042	CAT 7 S/FTP AWG 26/7	White	500
3360549042	CAT 7 S/FTP AWG 26/7	Orange	500
3360649042	CAT 7 S/FTP AWG 26/7	Blue	500
3360749042	CAT 7 S/FTP AWG 26/7	Red	500
3360849042	CAT 7 S/FTP AWG 26/7	Green	500
3361149042	CAT 7 S/FTP AWG 26/7	Black	1000
3361249042	CAT 7 S/FTP AWG 26/7	Yellow	1000
3361349042	CAT 7 S/FTP AWG 26/7	Grey	1000
3361449042	CAT 7 S/FTP AWG 26/7	White	1000
3361549042	CAT 7 S/FTP AWG 26/7	Orange	1000
3361649042	CAT 7 S/FTP AWG 26/7	Blue	1000
3361749042	CAT 7 S/FTP AWG 26/7	Red	1000
3361849042	CAT 7 S/FTP AWG 26/7	Green	1000

## PERFORMANCE:

F (MHz)	ATT (dB/100 m)	RL (dB)	NEXT (dB)	PS NEXT (dB)	ACRF (EL FEXT) (dB/100 m)	PS ACRF (PS EL FEXT) (dB/100 m)	PD (ns/100 m)
4.0	4.9	32	107	95	117	-	463
8.0	6.8	32	107	98	107	-	457
10.0	7.6	35	105	96	100	-	456
16.0	9.6	34	104	95	116	-	453
20.0	10.8	43	117	98	106	-	452
25.0	12.2	40	115	100	103	-	451
31.2	13.7	39	107	100	108	-	450
62.5	19.7	42	114	102	113	-	447
100.0	25.1	39	102	100	109	-	446
200.0	35.9	37	111	104	102	-	445
250.0	40.1	33	104	99	112	-	444
300.0	44.3	33	114	101	109	-	444
600.0	63.9	27	102	93	106	-	443

If FEXT loss is greater than 70 dB, PS ACR-F loss may not be measured

**F** = Frequency

**ATT** = Attenuation

**RL** = Return Loss

**NEXT** = Near End Crosstalk

**PS NEXT** = Power Sum Near End Crosstalk

**ACRF (EL FEXT)** = Attenuation to Crosstalk Ratio Far End Crosstalk

**PS ACRF (PS EL FEXT)** = Power Sum Attenuation to Crosstalk Ratio Far End Crosstalk

**PD** = Phase Delay

# CAT 7 PUR

## S/FTP 4 PR AWG 26/7



<b>CONDUCTOR</b>	Stranded tinned copper conductor 26 AWG/7
<b>INSULATION</b>	Foam PE
<b>PAIR SHIELDING</b>	Aluminium foil
<b>SHIELDING</b>	Tinned copper wire braid
<b>SHEATH</b>	Polyurethane compound
<b>REFERENCE STANDARD</b>	IEC 61156-6

### APPLICATION

Good mechanical characteristics, high tensile strength, resistant to UV, abrasion, chemicals, oil and other fluids

### PHYSICAL PROPERTIES:

<b>BENDING RADIUS (Installation)</b>	8 x Ø
<b>MAX. RECOMMENDED PULLING TENSION</b>	80 N
<b>NOMINAL OUTER Ø</b>	6.4 ± 0.3 mm
<b>CABLE WEIGHT</b>	39 kg/km
<b>CORE IDENTIFICATION Pair colours</b>	1. White/Blue stripe & Blue 2. White/Orange stripe & Orange 3. White/Green stripe & Green 4. White/Brown stripe & Brown
<b>PACKAGING</b>	500 m drum, 1000 m drum

### MAIN CHARACTERISTICS:

<b>FIRE PERFORMANCE</b>	IEC 60332-1
<b>HALOGEN-FREE</b>	IEC 60754 series
<b>MAX. CONDUCTOR DC RESISTANCE</b>	145 Ω/km @20 °C
<b>CONDUCTOR LOOP RESISTANCE</b>	max. 29 Ω/100 m @20 °C
<b>NOM. MUTUAL CAPACITANCE</b>	≤ 5.6 nF/100 m @1 kHz
<b>CAPACITANCE UNBALANCE PAIR TO GROUND</b>	≤ 1600 pF/km @1 kHz
<b>MIN. INSULATION RESISTANCE</b>	5000 MΩ/m
<b>IMPEDANCE</b>	100 ± 25 Ω @100 MHz
<b>RATED TEMPERATURE</b>	75 °C
<b>OPERATING TEMPERATURE RANGE</b>	-20 °C - 75 °C

## ITEM NUMBERS:

Part number	Cable type	Colour	Standard length m
3350149042	CAT 7 S/FTP AWG 26/7 PUR	Black	500
---	CAT 7 S/FTP AWG 26/7 PUR	Yellow	500
---	CAT 7 S/FTP AWG 26/7 PUR	Grey	500
---	CAT 7 S/FTP AWG 26/7 PUR	White	500
---	CAT 7 S/FTP AWG 26/7 PUR	Orange	500
---	CAT 7 S/FTP AWG 26/7 PUR	Blue	500
---	CAT 7 S/FTP AWG 26/7 PUR	Red	500
---	CAT 7 S/FTP AWG 26/7 PUR	Green	500
3351149042	CAT 7 S/FTP AWG 26/7 PUR	Black	1000
---	CAT 7 S/FTP AWG 26/7 PUR	Yellow	1000
---	CAT 7 S/FTP AWG 26/7 PUR	Grey	1000
---	CAT 7 S/FTP AWG 26/7 PUR	White	1000
---	CAT 7 S/FTP AWG 26/7 PUR	Orange	1000
---	CAT 7 S/FTP AWG 26/7 PUR	Blue	1000
---	CAT 7 S/FTP AWG 26/7 PUR	Red	1000
---	CAT 7 S/FTP AWG 26/7 PUR	Green	1000

## PERFORMANCE:

F (MHz)	ATT (dB/100 m)	RL (dB)	NEXT (dB)	PS NEXT (dB)	ACRF (EL FEXT) (dB/100 m)	PS ACRF (PS EL FEXT) (dB/100 m)	PD (ns/100 m)
4.0	4.9	32	107	95	117	-	463
8.0	6.8	32	107	98	107	-	457
10.0	7.6	35	105	96	100	-	456
16.0	9.6	34	104	95	116	-	453
20.0	10.8	43	117	98	106	-	452
25.0	12.2	40	115	100	103	-	451
31.2	13.7	39	107	100	108	-	450
62.5	19.7	42	1114	102	113	-	447
100.0	25.1	39	102	100	109	-	446
200.0	35.9	37	111	104	102	-	445
250.0	40.1	33	104	99	112	-	444
300.0	4.3	33	114	101	109	-	444
600.0	63.9	27	102	93	106	-	443

If FEXT loss is greater than 70 dB, PS ACR-F loss may not be measured

**F** = Frequency

**ATT** = Attenuation

**RL** = Return Loss

**NEXT** = Near End Crosstalk

**PS NEXT** = Power Sum Near End Crosstalk

**ACRF (EL FEXT)** = Attenuation to Crosstalk Ratio Far End Crosstalk

**PS ACRF (PS EL FEXT)** = Power Sum Attenuation to Crosstalk Ratio Far End Crosstalk

**PD** = Phase Delay

# CAN-BUS

1 X 2 X 0.75 120 Ω



<b>CONDUCTOR</b>	Flexible tinned copper conductor 0.75 mm <sup>2</sup>
<b>INSULATION</b>	PE
<b>STRANDING</b>	Two cores form a pair
<b>SCREEN</b>	Tinned copper wire braid Coverage 80%
<b>OUTER SHEATH</b>	LSZH
<b>COLOUR</b>	Violet

## PHYSICAL PROPERTIES:

<b>BENDING RADIUS</b>	5 x Ø
<b>NOMINAL OUTER Ø</b>	8.7 ± 0.3 mm
<b>CABLE WEIGHT</b>	90 kg/km
<b>CORE IDENTIFICATION</b>	
<b>Pair colours</b>	1. White 2. Brown
<b>PART NUMBER</b>	29994

## MAIN CHARACTERISTICS:

<b>FIRE PERFORMANCE</b>	IEC 60332-1-2 IEC 60332-3-22
<b>OPERATING VOLTAGE</b>	30 V
<b>TEST VOLTAGE</b>	1000 V
<b>HALOGEN FREE</b>	IEC 60754 series
<b>SMOKE EMISSION</b>	IEC 61034 series
<b>CHARACTERISTIC IMPEDANCE</b>	120 ± 12 Ω @1 MHz
<b>OPERATING TEMPERATURE RANGE</b>	-25 °C - 80 °C

# CAN-BUS

2 X 2 X 0.75 120 Ω

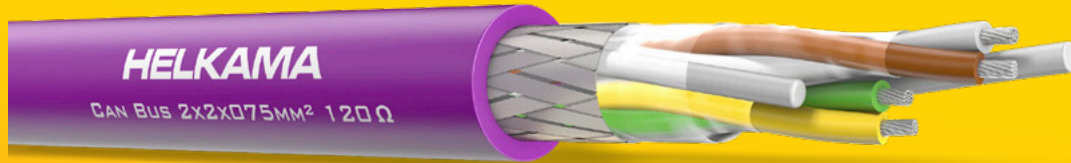

<b>CONDUCTOR</b>	Flexible tinned copper conductor 0.75 mm <sup>2</sup>
<b>INSULATION</b>	PE
<b>STRANDING</b>	Two cores form a pair (two pairs) with fillers to obtain symmetrical and round construction
<b>SCREEN</b>	Tinned copper wire braid Coverage 80%
<b>OUTER SHEATH</b>	LSZH
<b>COLOUR</b>	Violet

## PHYSICAL PROPERTIES:

<b>BENDING RADIUS</b>	5 x Ø
<b>NOMINAL OUTER Ø</b>	11.5 ± 0.3 mm
<b>CABLE WEIGHT</b>	154 kg/km
<b>CORE IDENTIFICATION</b>	
<b>Pair colours</b>	1. White 2. Brown 3. Yellow 4. Green
<b>PART NUMBER</b>	29995

## MAIN CHARACTERISTICS:

<b>FIRE PERFORMANCE</b>	IEC 60332-1-2 IEC 60332-3-22
<b>OPERATING VOLTAGE</b>	30 V
<b>TEST VOLTAGE</b>	1000 V
<b>HALOGEN FREE</b>	IEC 60754 series
<b>SMOKE EMISSION</b>	IEC 61034 series
<b>CHARACTERISTIC IMPEDANCE</b>	120 ± 12 Ω @1 MHz
<b>OPERATING TEMPERATURE RANGE</b>	-25 °C - 80 °C

# PROFIBUS DP

## 1 X 2 X AWG 22/7 -HF

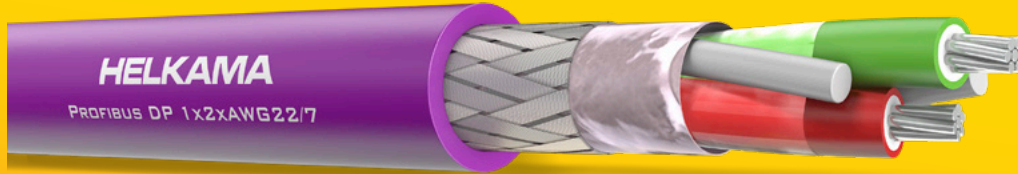

<b>CONDUCTOR</b>	Stranded tinned copper conductor AWG 22/7
<b>INSULATION</b>	Foam-Skin-PE
<b>STRANDING</b>	Two cores stranded together with 2 fillers
<b>SCREEN 1</b>	Aluminium polyester tape
<b>SCREEN 2</b>	Tinned copper wire braid
<b>OUTER SHEATH</b>	LSZH
<b>COLOUR</b>	Violet

### PHYSICAL PROPERTIES:

<b>BENDING RADIUS</b>	5 x Ø
<b>NOMINAL OUTER Ø</b>	7.8 ± 0.2 mm
<b>CABLE WEIGHT</b>	70 kg/km
<b>CORE IDENTIFICATION</b>	1. Red 2. Green
<b>PART NUMBER</b>	29996

### MAIN CHARACTERISTICS:

<b>FIRE PERFORMANCE</b>	IEC 60332-1-2 IEC 60332-3-22
<b>HALOGEN FREE</b>	IEC 60754 series
<b>SMOKE EMISSION</b>	IEC 61034 series
<b>MAXIMUM RESISTANCE CONDUCTOR (LOOP)</b>	≤ 110 Ω/km
<b>CHARACTERISTIC IMPEDANCE</b>	150 Ω ± 10%
<b>MUTUAL CAPACITANCE</b>	30 nF/km
<b>ATTENUATION</b>	9.6 kHz ≤ 2.5 dB/km 38.4 kHz ≤ 4.0 dB/km 4.0 MHz ≤ 22.0 dB/km 16.0 MHz ≤ 42.0 dB/km
<b>OPERATING TEMPERATURE RANGE</b>	-25 °C - 70 °C





# CHARACTERISTICS OF OPTICAL FIBER CABLES

## SINGLE-MODE FIBER

Conditions		SM/OS2	Unit
Standards according to ITU-T		<b>G.652.D</b>	
Attenuation (max)	1310 nm	≤ 0.40	dB/km
	1550 nm	≤ 0.30	dB/km
Cut-off wavelength		≤ 1260	nm
Cut-off wavelength installation		1180 – 1250	nm
Zero dispersion wavelength		1300 – 1324	nm
Zero dispersion slope		≤ 0.092	ps/nm <sup>2</sup> /km
Polarization mode dispersion		≤ 0.5	ps/√km
Mode field diameter (MFD)	1310 nm	9.1 ± 0.4	μm
	1550 nm	10.3 ± 0.4	μm
Mode field eccentricity		≤ 1.0	μm
Mode field eccentricity, installation		≤ 0.5	μm
Cladding diameter		125 ± 2	μm
Cladding diameter, installation		125 ± 1	μm
Cladding ellipticity		≤ 1	%

## MULTI MODE FIBER

Conditions					Unit
Fiber class		<b>GK/OM1</b>	<b>OM3</b>	<b>OM4</b>	
		GKL 250 ± 10	OM3L 250 ± 10	OM4L 250 ± 10	µm
		GKT 900 ± 50	OM3T 900 ± 50	OM4T 900 ± 50	µm
Attenuation (max)	850 nm	3.0	2.7	2.5	dB/km
	1300 nm	≤ 1.0	≤ 0.8	≤ 0.8	dB/km
Bandwidth	850 nm (LED)	≥ 200	≥ 1500	≥ 3500	MHz x km
	1300 nm (LED)	≥ 500	≥ 500	≥ 500	MHz x km
	850 nm (Laser)		≥ 2000	≥ 4700	MHz x km
Numerical aperture (NA)		0.275 ± 0.015	0.200 ± 0.015	0.200 ± 0.015	
Core diameter		62.5 ± 3	50 ± 2	50 ± 2.5	µm
Core ellipticity		≤ 6	≤ 6	≤ 6	%
Core eccentricity		≤ 3	≤ 3	≤ 2	µm
Cladding diameter		125 ± 2	125 ± 1	125 ± 1	µm
Cladding ellipticity		≤ 2	≤ 2	≤ 2	%

# GENERAL INFORMATION

## MATERIALS

### INSULATION MATERIALS

#### XLPE

Cross-linked polyethylene compound.  
Excellent mechanical and electrical characteristics

#### PE

Polyethylene thermoplastic compound

### SHEATHING MATERIALS

#### LSZH THERMOPLASTIC

Low smoke zero halogen thermoplastic compound.  
Flame retardant and self-extinguishing in the event of fire.

#### SHF1

LSZH thermoplastic. Low smoke zero halogen thermoplastic compound. Flame retardant and self-extinguishing in the event of fire.

#### SHF2

Crosslinked thermoset plastic. Low smoke zero halogen cross-linked thermoset oil-resistant compound. Flame retardant and self-extinguishing in the event of fire.

### MARKING ON THE SHEATH

Lot number, Cable type, Cable size (number of cores x size of conductors mm<sup>2</sup>), Voltage, Temperature, Standards, Manufacturer's name, Production month and year, Meter marking.

## TESTS AND DEFINITIONS OF TERMS

### CPR CABLE CLASSIFICATION

B2ca, Cca, Dca, Eca

Analyses the reaction of electrical cables to fire. Four classes apply directly to electrical cables, classified according to their flame spread and heat release.

#### ADDITIONAL CLASSIFICATION LEVELS: s, d, a

Three additional CPR classification levels refer to:

s = smoke	The opacity and amount of smoke produced
d = droplets	The flaming droplets released by the cable during combustion
a = acidity	The acidity of the smoke

### HALOGEN-FREE

Halogen-free refers to the absence of halogens, such as chlorine and fluorine. Determined on the basis of the halogen content and the acidity of cable's gases.

Halogen-free IEC 60754-series consists of standards IEC 60754-1 and IEC 60754-2.

#### IEC 60754-1

Determines halogen content of material. Halogen content of material may not exceed 0.5% or 5 mg/g.

#### IEC 60754-2

Determines degree of acidity of combustion gases. Limit values > 4.3 for pH and < 10 µS/mm for conductivity.

### SMOKE EMISSION

#### IEC 61034-1, IEC 61034-2

Smoke emission refers to visibility in a fire. Greater light transmittance means better visibility.

Smoke Emission IEC 61034-series consists of standards IEC 61034-1 and IEC 61034-2.

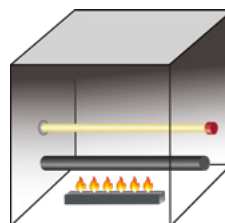

**27 m<sup>3</sup> cube  
smoke chamber**

*Requirements: 60% light transmittance*



## FIRE PERFORMANCE

### IEC 60332-1, IEC 60332-3

Cables must withstand the test specified in IEC standard 60332-3 or IEC 60332-1. Flame-retardant cables do not propagate fire and are self-extinguishing.

### IEC 60332-1

Test for single cable. Test procedure and requirements according to picture below.

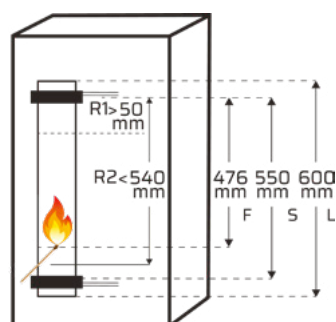

*Min. 50 mm of the cable, measured from the upper support, must remain unburned after the specified time.*

### IEC 60332-3

Test for bunched cables with three categories - A, B and C. Categories are defined by different limits for flammable material and burning times. Cables must extinguish themselves once the burner has been removed.

Test procedure and requirements according to picture below.

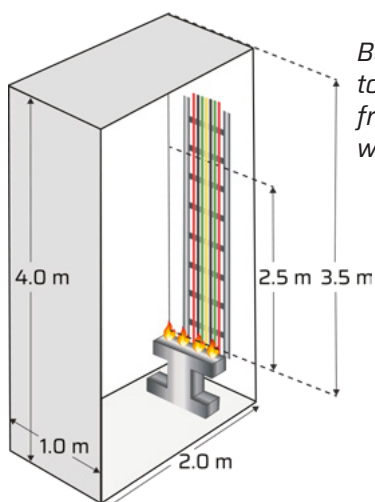

*Burning allowed up to max. 2.5 meters from the burner within a specified time.*

## FIRE-RESISTANT

Helkama fire-resistant cables are also flame-retardant.

### IEC 60331-21

Cables must operate for min. 90 minutes while subjected to fire from burner.

### IEC 60331-25

Cables must operate for min. 180 minutes while subjected to fire from burner.

### IEC 60331-1

Test method for fire with shock at a temperature of min. 830 °C for 180 minutes for cables with rated voltage up to and including 0.6/1.0 kV, and with  $\varnothing > 20$  mm.

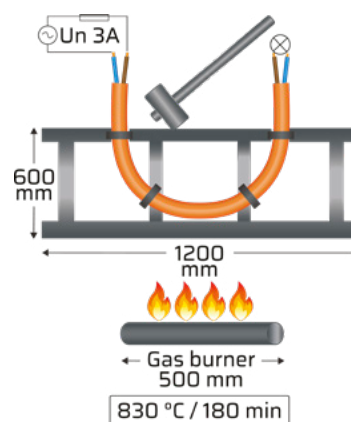

### IEC 60331-2

Test method for fire with shock at a temperature of min. 830 °C for 180 minutes for cables with rated voltage up to and including 0.6/1.0 kV, and with  $\varnothing < 20$  mm.

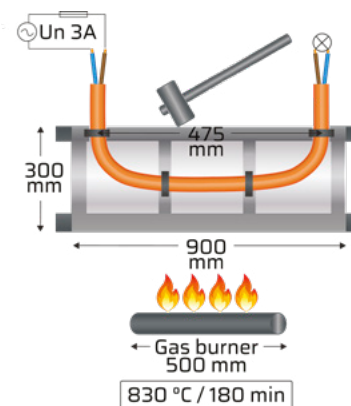





Subject to change without prior notice. See latest update on our webpage.

© 2022 Helkama Bica Oy. All rights reserved.

**HELKAMA**  
THE PERFECT CONNECTION

helkamabica.com  
customer.care@helkamabica.fi  
+358 2 410 8700







## HELKAMA BICA OY

Lasitehtaankatu 12  
FI-10960 HANKO

Tel. +358 2 410 8700

firstname.lastname@helkamabica.fi  
customer.care@helkamabica.fi

## THE PERFECT CONNECTION

[www.helkamabica.com](http://www.helkamabica.com)